

Catalogo parti di ricambio
Spare parts catalogue
Catalogue pieces de rechange
Ersatzteilliste

MD150 MD151
MD190 MD191



TAVOLA/TABLE

1 BASAMENTO
CRANKCASE
CARTER MOTEUR
KURBELGEHÄUSE

2 MANOVELLISMO
CRANK MECHANISM
EQUIPAGE MOBILE
KURBELGETRIEBE

3 REGOLATORE GIRI
GOVERNOR
REGULATEUR DE TOURS
REGLER

4 TESTA CILINDRO
CYLINDER HEAD - CYLINDER
CULASSE - ZYLINDER
ZYLINDERKOPF - ZYLINDER

5 POMPA INIEZIONE E INIETTORE
INJECTION PUMP AND INJECTOR
POMPE A INJECTION-PORTE INJECTEUR
EINSPRITZPUMPE UND EINSPRITZDÜSE

6 RAFFREDDAMENTO
COOLING
REFROIDISSEMENT
LUFTKÜHLUNG

7 AVVIAMENTO ELETTRICO
ELECTRICAL STARTING
DEMARRAGE ELECTRIQUE
ELEKTRISCHER ANLASSER

8 RADIATORE OLIO
OIL COOLER
RADIATEUR HUIL
KÜHLER

9 ACCESSORI A RICHIESTA
FITTINGS UPON REQUEST
ACCESSOIRES SUR DEMANDE
RUBEHÖRE AUF WUNSCH

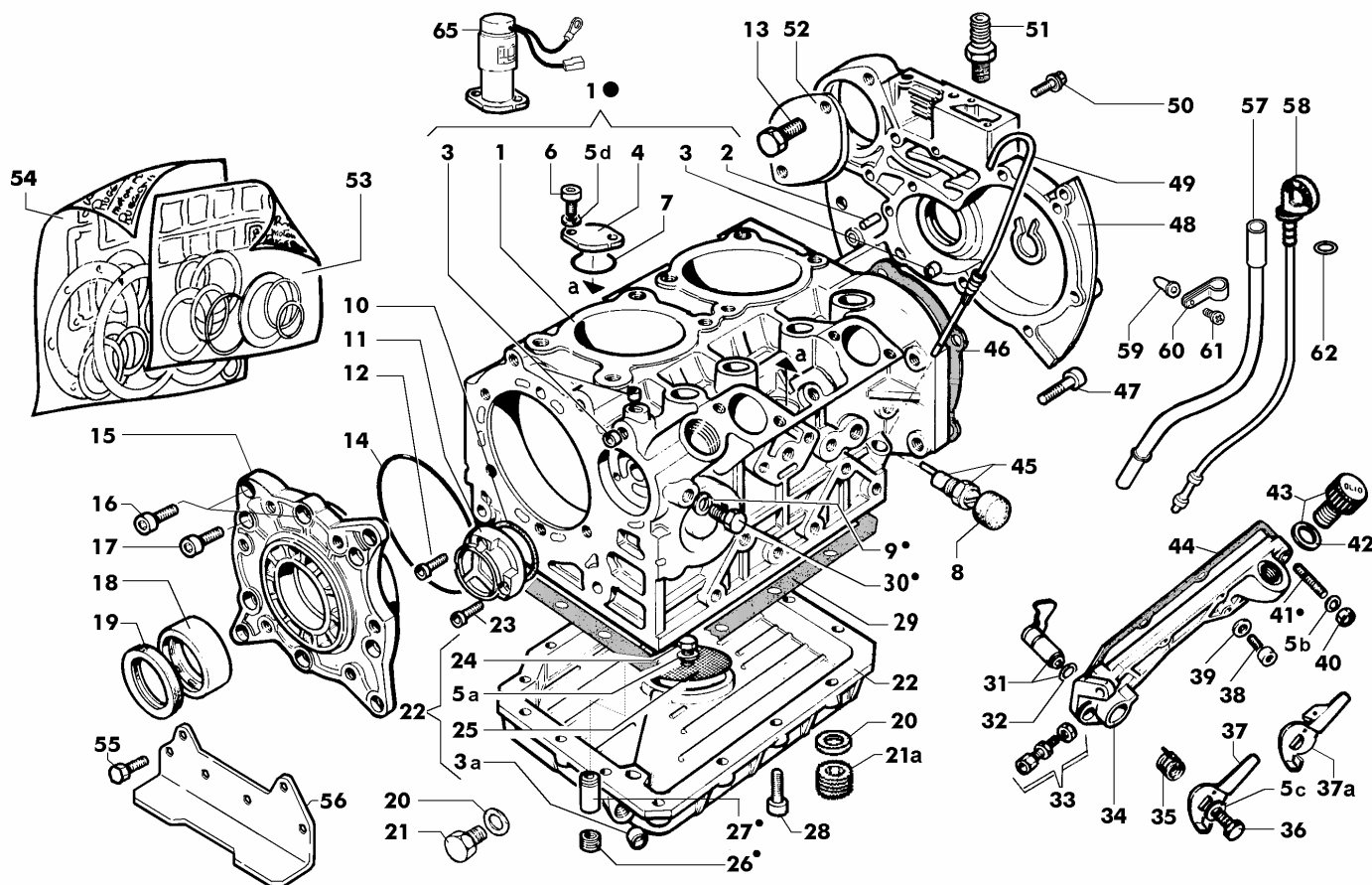

Nr. No.	CODE	MD	MD	MD	MD	DENOMINAZIONE - DESCRIPTION - DENOMINATION - BENENNUNG	CT No		
		150 Q.ty	151 Q.ty	190 Q.ty	191 Q.ty				
	00C25R0120	1	1	—	—	Blocco motore	Short block	Bloc moteur	Motorbloken
	00C25R0620	—	—	1	1	Blocco motore	Short block	Bloc moteur	Motorbloken
1	00A21R0700	1	1	—	—	Carter motore	Crankcase	Carter Moteur	Kurbelgehäuse
	00A23R0180	—	—	1	1	Carter motore	Crankcase	Carter Moteur	Kurbelgehäuse
2	0084001200	1	1	1	1	Spina cilindrica D.8x14	Taper pin	Goupille	Kegelstift
3	0089900580	4	4	4	4	Tappo a scodellino	Plug	Bouchon	Verschluß
3a	00886R0570	1	1	1	1	Tappo chiusura D.12	Plug	Bouchon	Verschluß
4	00399R0860	1	1	1	1	Flangia	Flange	Bride	Flansch
5a	0076250080	1	1	1	1	Rondella piana D.12x6,5	Washer	Rondelle	Unterlegscheibe
5b	0076250080	1	1	1	1	Rondella piana D.12x6,5	Washer	Rondelle	Unterlegscheibe
5c	0076250080	1	1	1	1	Rondella piana D.12x6,5	Washer	Rondelle	Unterlegscheibe
5d	0076250080	2	2	2	2	Rondella piana D.12x6,5	Washer	Rondelle	Unterlegscheibe
6	0097320840	2	2	2	2	Vite M 6 x 12	Screw	Vis	Schraube
7	00579R0790	1	1	1	1	Anello OR D.33,05	O-ring	Joint torique	O-Ring
8	—	—	—	—	—	-Non disponibile-	-Not available-	-Ne pas disponible-	-Nicht vorrätig-
9	0046700580	2	2	2	2	Rondella rame D.8,2x12 sp.1	Washer	Rondelle	Unterlegscheibe
10	00579R0490	1	1	1	1	Anello OR D.41.00 sez.1,78	O-ring	Joint torique	O-Ring
11	00233R0860	1	1	1	1	Coperchio sede pompa olio	Cover	Couvercle	Deckel
12	00992R0190	1	1	1	1	Vite M.5x25	Screw	Vis	Schraube
13	0017800300	2	2	—	—	Vite TE. 10x20	Screw	Vis	Schraube
14	00579R0780	1	1	1	1	Anello OR D.113,97	O-ring	Joint torique	O-Ring
15	0086753000	1	1	1	1	Supporto di banco	Support	Support	Lager
16	0097320920	2	2	2	2	Vite M 8 x 18	Screw	Vis	Schraube
17	0097301180	8	8	8	8	Vite	Screw	Vis	Schraube
18	00310R0770	1	1	1	1	Cuscinetto di banco STD	Bearing	Roulement	Lager
	00310R0800	1	1	1	1	Cuscinetto di banco -0,25 mm	Bearing	Roulement	Lager
	00310R0810	1	1	1	1	Cuscinetto di banco -0,50 mm	Bearing	Roulement	Lager
19	00A21R0250	1	1	1	1	Kit anelli tenuta olio	Oil seal	Bague étanchéité	Dichtring
20	0046700610	2	2	2	2	Guarnizione in rame d.14	Gasket	Joint	Dichtung
21	0089650050	1	1	1	1	Tappo M,14x1,5 L.15	Plug	Bouchon	Verschluß



**BASAMENTO - CRANKCASE
CARTER MOTEUR - KURBELGEHÄUSE**

CATALOGO RICAMBI SPARE PARTS	
TAVOLA TABLE	1 2
DATA DATE	10/2007

Nr. No.	CODE	MD	MD	MD	MD	DENOMINAZIONE - DESCRIPTION - DENOMINATION - BENENNUNG	CT No
		150 Q.ty	151 Q.ty	190 Q.ty	191 Q.ty		
21a	0090400120	1	1	1	1	Tappo M 14 Plug Bouchon Verschluss	
22	0066456960	1	1	1	1	Coppa olio con due scarichi Oil pan 2 oil discharging Carter huile 2 bouchon Ölwanne	
	00A21R0240	1	1	1	1	Coppa olio in alluminio Oil Pan Carter Huile Ölwanne	
23	00992R0190	2	2	2	2	Vite M.5x25 Screw Vis Schraube	
24	0017601300	1	1	1	1	Bullone M 6 X 1 X 12 Bolt Boulon Stehbolzen	
25	00734R0720	1	1	1	1	Rete aspirazione coppa olio Net Grillage Netz	
26	00999R0200	1	1	1	1	Vite M.16x1,5x10 Screw Vis Schraube	
27	00956R0450	1	1	1	1	Valvola by-pass Valve Soupape Ventil	
28	0017601380	15	15	15	15	Vite M.6x30 Screw Vis Schraube	
29	00450R0600	1	1	1	1	Guarnizione coppa olio Gasket Joint Dichtung	
30	00995R0160	2	2	2	2	Vite vte M.8x1x10 Screw Vis Schraube	
31	00494R0880	1	1	1	1	Leva stop completa Lever Lever Hebel	
32	00579R0010	1	1	1	1	Anello OR d.8.73 sez.1,78 O-ring Joint torique O-Ring	
33	0091801910	1	1	1	1	Registro tendi filo Setscrew Vis réglage Einstellschraube	
34	00235R0050	1	1	1	1	Coperchio tirante p.iniezione completo Cover ass.y Couvercle complet Komplettdeckel	250008R
	0027505030	1	1	1	1	Coperchio tirante p.iniezione completo Cover ass.y Couvercle complet Komplettdeckel	
35	00547R0280	1	1	1	1	Molla richiamo leva stop Spring Ressort Feder	
36	0017600030	1	1	1	1	Vite M.6x12 Screw Vis Schraube	
37	00494R0860	1	1	1	1	Leva esterna stop Lever Lever Hebel	
37a	00491R0670	1	1	1	1	Leva esterna stop Lever Lever Hebel	
38	0097320780	5	5	5	5	Vite M6x25 Screw Vis Schraube	
39	0046700580	1	1	1	1	Rondella rame D.8,2x12 sp.1 Washer Rondelle Unterlegscheibe	
40	00323R0070	1	1	1	1	Dado M.6 h.6 Nut Écrou Mutter	
41	0067600340	1	1	1	1	Prigioniero M.6x18 r.6/3/15 Stud Goujon Stiftschraube	
42	00758R0390	1	1	1	1	Rondella in gomma D.22 x 27 sp.2 Washer Rondelle Unterlegscheibe	
43	0090320950	1	1	1	1	Tappo carico olio Threaded plug Bouchon fileté Verschlußschraube	
44	00453R0770	1	1	1	1	Guarnizione Gasket Joint Dichtung	
45	00722R0240	1	1	1	1	Registro suppl.coppia Setscrew Vis réglage Einstellschraube	
46	0044311760	1	1	1	1	Guarnizione cop. distribuzione Gasket Joint Dichtung	
47	0097320640	10	10	10	10	Vite M.8 x 30 Screw Vis Schraube	
48	00240R0450	1	1	1	1	Coperchio distribuzione Cover Couvercle Deckel	
49	00076R0480	1	1	1	1	Asta livello olio Rod Tige Stange	
50	0017601310	1	1	1	1	Bullone M 6 x 20 Bolt Boulon Schraube	
51	00717R0800	1	1	1	1	Raccordo per sfiato Union Raccord Anschlußstück	
52	0063000210	1	1	—	—	Coperchio sede motorino avviam. Cover Couvercle Deckel	
53	00A21R0410	1	1	—	—	Serie guarnizioni smeriglio Hoveraul gasket set Joint Dichtung	
	00A22R0920	—	—	1	1	Serie guarnizioni smeriglio Hoveraul gasket set Joint Dichtung	
54	00A21R0420	1	1	—	—	Serie guarnizioni completa Complete gasket set Joint Dichtung	
	00A22R0910	—	—	1	1	Serie guarnizioni completa Complete gasket set Joint Dichtung	
55	0017700040	12	12	12	12	Vite M8 Screw Vis Schraube	
56	00626R0030	2	2	2	2	Piede Engine mount Pied Fuß	
57	00940R0340	—	—	1	1	Tubo asta livello Dipstick guard Tube jauge niveau Ölpeilstabrohr	
58	00076R0500	—	—	1	1	Asta livello olio Oil dipstick Jauge huile Meßstadi	
59	00742R0150	—	—	1	1	Rivetto filettato M.6 Rivet Rivet Niete	
60	0036170880	—	—	1	1	Fascetta Clamp Collier Schelle	
61	0097900470	—	—	1	1	Vite M.6x16 Capscrew Vis Schraube	
62	0012002740	—	—	1	1	Anello OR d.8,00 Oil seal Bague en caoutchouc O-Ring	
65	00674R0470	1	1	1	1	Elettrostop 12V Elettrostop Elettrostop Elettrostop	
	00674R0680	1	1	1	1	Elettrostop 24V Elettrostop Elettrostop Elettrostop	

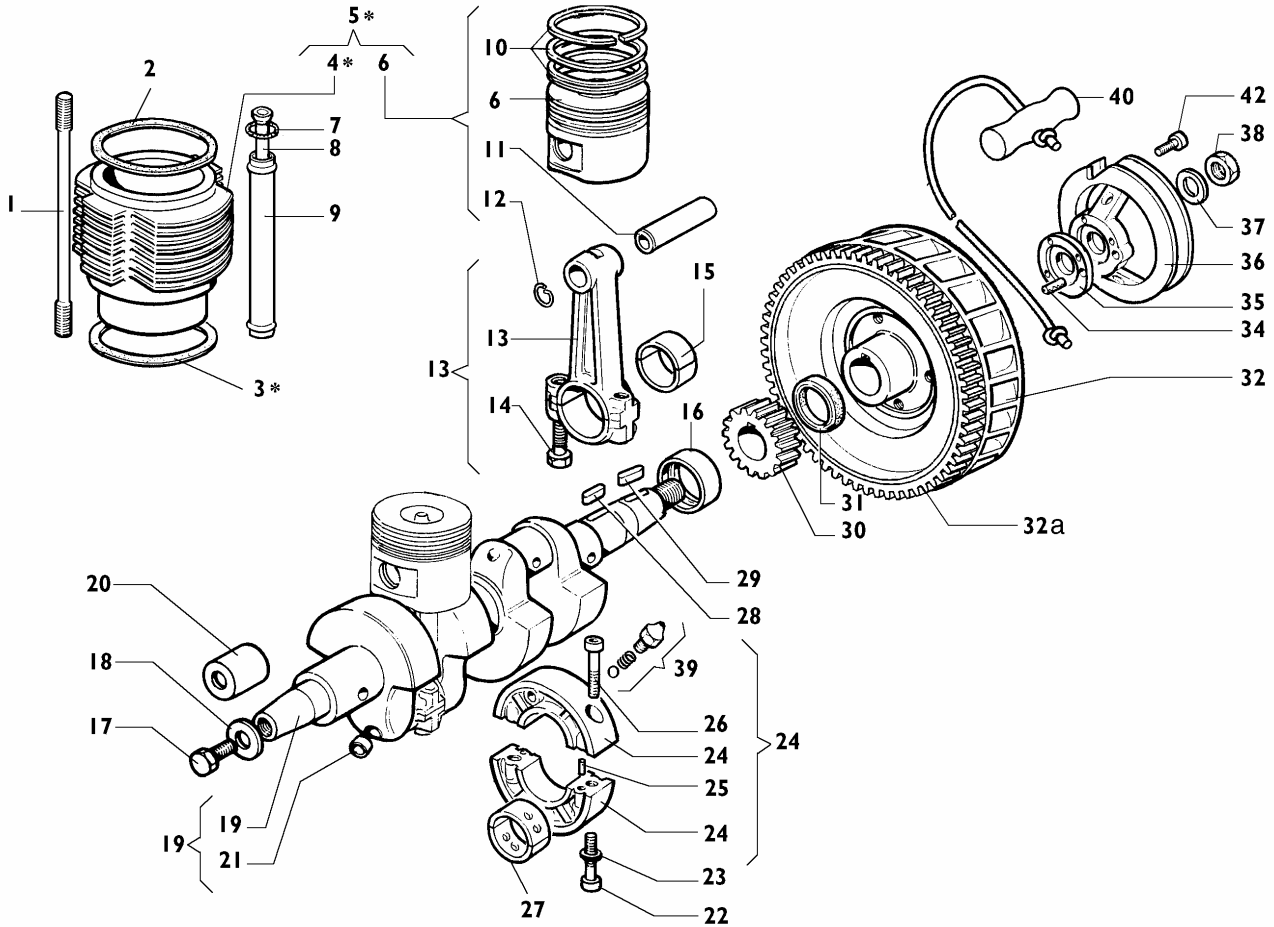

Nr. No.	CODE	MD	MD	MD	MD	DENOMINAZIONE - DESCRIPTION - DENOMINATION - BENENNUNG	CT No			
		150 Q.ty	151 Q.ty	190 Q.ty	191 Q.ty					
1	00684R0260	8	8	—	—	Prigioniero cilindro	Stud	Goujon	Stiftschraube	
	00684R0340	—	—	8	8	Prigioniero cilindro	Stud	Goujon	Stiftschraube	
2	0047307830	2	2	—	—	Guarnizione testa 0,80	Gasket	Joint	Dichtung	250001R
	0047307840	2	2	—	—	Guarnizione testa 0,85	Gasket	Joint	Dichtung	250001R
	0047307850	2	2	—	—	Guarnizione testa 0,90	Gasket	Joint	Dichtung	250001R
	0047307860	2	2	—	—	Guarnizione testa 0,95	Gasket	Joint	Dichtung	250001R
	0047307870	2	2	—	—	Guarnizione testa 1,00	Gasket	Joint	Dichtung	250001R
	0047307880	2	2	—	—	Guarnizione testa 1,05	Gasket	Joint	Dichtung	250001R
	0047307890	2	2	—	—	Guarnizione testa 1,10	Gasket	Joint	Dichtung	250001R
	0047307790	2	2	—	—	Guarnizione testa 1,15	Gasket	Joint	Dichtung	250001R
	0047307800	2	2	—	—	Guarnizione testa 1,20	Gasket	Joint	Dichtung	250001R
	0047307810	2	2	—	—	Guarnizione testa 1,25	Gasket	Joint	Dichtung	250001R
	0047307820	2	2	—	—	Guarnizione testa 1,30	Gasket	Joint	Dichtung	250001R
	0047308880	—	—	2	2	Guarnizione testa 0,80	Gasket	Joint	Dichtung	250001R
	0047308890	—	—	2	2	Guarnizione testa 0,85	Gasket	Joint	Dichtung	250001R
	0047308900	—	—	2	2	Guarnizione testa 0,90	Gasket	Joint	Dichtung	250001R
	0047308910	—	—	2	2	Guarnizione testa 0,95	Gasket	Joint	Dichtung	250001R
	0047308920	—	—	2	2	Guarnizione testa 1,00	Gasket	Joint	Dichtung	250001R
	0047308930	—	—	2	2	Guarnizione testa 1,05	Gasket	Joint	Dichtung	250001R
	0047308940	—	—	2	2	Guarnizione testa 1,10	Gasket	Joint	Dichtung	250001R
	0047308840	—	—	2	2	Guarnizione testa 1,15	Gasket	Joint	Dichtung	250001R
	0047308850	—	—	2	2	Guarnizione testa 1,20	Gasket	Joint	Dichtung	250001R
	0047308860	—	—	2	2	Guarnizione testa 1,25	Gasket	Joint	Dichtung	250001R
	0047308870	—	—	2	2	Guarnizione testa 1,30	Gasket	Joint	Dichtung	250001R
3	—	—	—	—	—	-Non disponibile-	-Not available-	-Ne pas disponible-	-Nicht vorrätig-	250001R
4	00203R0980	2	2	—	—	Cilindro D.80	Cylinder	Cylindre	Zylinder	
	00204R0470	—	—	2	2	Cilindro D.85	Cylinder	Cylindre	Zylinder	250005R
5	00A23R0420	2	2	—	—	Kit cilindro-pistone	Cylinder-piston	Cylindre-piston	Zylinder-kolben	
	00A26R0610	—	—	2	2	Kit cilindro-pistone	Cylinder-piston	Cylindre-piston	Zylinder-kolben	250005R
6	00A21R0280	2	2	—	—	Pistone D.80	Piston	Piston	Kolben	
	00A26R0600	—	—	2	2	Pistone D.85	Piston	Piston	Kolben	250005R



**MANOVELLISMO - CRANK MECHANISM
EQUIPAGE MOBILE - KURBELGETRIEBE**

CATALOGO RICAMBI SPARE PARTS		
TAVOLA TABLE	2	2
DATA DATE	10/2007	

Nr. No.	CODE	MD	MD	MD	MD	DENOMINAZIONE - DESCRIPTION - DENOMINATION - BENENNUNG	CT No			
		150 Q.ty	151 Q.ty	190 Q.ty	191 Q.ty					
7	0012000060	8	8	8	8	Anello OR 121 D.15,88	O-ring	Joint torique	O-Ring	
8	00072R0030	4	4	—	—	Asta bilancieri completa	Rod	Tige	Stange	
	00072R0100	—	—	4	4	Asta bilancieri completa	Rod	Tige	Stange	
9	00940R0280	4	4	—	—	Tube custodia aste bilancieri	Protection pipe	Tuyau protection	Schutzrohr	
	00940R0380	—	—	4	4	Tube custodia aste bilancieri	Protection pipe	Tuyau protection	Schutzrohr	
10	00A21R0320	2	2	—	—	Serie segmenti	Piston rings	Segments	Kolben ring	
	00A26R0650	—	—	2	2	Serie segmenti D.85	Crankcase	Carter Moteur	Kurbelgehäuse	250005R
11	00854R0180	2	2	—	—	Spinotto D.20x60 foro 12	Piston pin	Axe du piston	Kolbenbolzen	
	00854R0170	—	—	2	2	Spinotto ø22x64 foro 12	Piston pin	Axe du piston	Kolbenbolzen	
12	00059R0860	4	4	—	—	Anello fermo spinotto ø23	Ring	Bague	Ring	
	0011600530	—	—	4	4	Anello fermo spinotto ø25	Ring	Bague	Ring	
13	00100R0410	2	2	—	—	Biella completa	Connecting Rod	Bielle	Pleuelstange	
	00100R0450	—	—	2	2	Biella completa	Connecting Rod	Bielle	Pleuelstange	
14	0017701010	4	4	4	4	Bullone M 8 x 1 x 42	Bolt	Boulon	Stehbolzen	
15	00A26R0370	2	2	2	2	Cuscinetto testa biella STD	Bearing	Roulement	Lager	
	00A26R0400	2	2	2	2	Cuscinetto testa biella -0,25 mm	Bearing	Roulement	Lager	
	00A26R0410	2	2	2	2	Cuscinetto testa biella -0,50 mm	Bearing	Roulement	Lager	
16	00310R0770	1	1	1	1	Cuscinetto di banco STD	Bearing	Roulement	Lager	
	00310R0800	1	1	1	1	Cuscinetto di banco -0,25 mm	Bearing	Roulement	Lager	
	00310R0810	1	1	1	1	Cuscinetto di banco -0,50 mm	Bearing	Roulement	Lager	
17	00993R0650	1	1	1	1	Vite M.14x1,5x40	Screw	Vis	Schraube	
18	00771R0390	1	1	1	1	Rondella piana D.14,5x35 sp.3,5	Washer	Rondelle	Unterlegscheibe	
19	00A21R0260	1	1	—	—	Albero a gomito completo	Crankshaft	Vilebrequin	Kurbelwelle	
	00A23R0160	—	—	1	1	Albero a gomito completo	Crankshaft	Vilebrequin	Kurbelwelle	
20	00886R0490	1	1	1	1	Tappo pretezione albero	Plug	Bouchon	Verschluß	
21	0090801320	4	4	4	4	Tappo d.6	Plug	Bouchon	Verschluß	
22	0097300320	2	2	2	2	Vite M.8x45	Screw	Vis	Schraube	
23	0076250100	2	2	2	2	Rondella piana 8x15	Washer	Rondelle	Unterlegscheibe	
24	00880R0260	1	1	—	—	Supporto di banco centrale	Support	Support	Lager	
	00880R0630	—	—	1	1	Supporto di banco centrale	Support	Support	Lager	
25	0084000200	2	2	2	2	Spina cilindrica D.6x12	Taper pin	Goupille	Kegelstift	
26	0097300310	2	2	2	2	Vite M 8 x 40	Screw	Vis	Schraube	
27	00A26R0490	1	1	1	1	Cuscinetto di banco STD	Bearing	Roulement	Lager	
	00A26R0500	1	1	1	1	Cuscinetto di banco -0,25 mm	Bearing	Roulement	Lager	
	00A26R0510	1	1	1	1	Cuscinetto di banco -0,50 mm	Bearing	Roulement	Lager	
28	00498R0230	1	1	1	1	Linguetta 6x6x12	Tab	Languette	Federkeil	
29	00498R0190	1	1	1	1	Linguetta 6x6x25	Tab	Languette	Federkeil	
30	00469R0640	1	1	1	1	Ingranaggio albero a gomito	Gear	Engrenage	Zahnrad	
31	00A21R0250	1	1	1	1	Kit anelli tenuta olio	Oil seal	Bague étanchèité	Dichtring	
32	0098814750	1	1	—	—	Volano con corona	Flywheel	Volant	Schwungrad	250003R
	0098814770	—	—	1	1	Volano con corona	Flywheel	Volant	Schwungrad	250003R
32a	00256R0140	1	1	1	1	Corona avviamento	Ring Gear	Couronne Démarrage	Starterkranz	
34	0084300140	1	1	—	—	Spina elastica D.6x16	Taper pin	Goupille	Kegelstift	
	00850R0010	—	—	1	1	Spina elastica D.6x30	Taper pin	Goupille	Kegelstift	
35	0035150390	—	—	1	1	Distanziale puleggia	Spacer	Entretoise	Distanzstück	
36	00697R0270	1	1	1	1	Puleggia avviamento D.32	Pulley	Poulie	Riemenscheibe	
37	00771R0280	1	1	—	—	Rondella piana D.23x40 sp.4	Washer	Rondelle	Unterlegscheibe	
	00771R0630	—	—	1	1	Rondella piana D.32,5x44 sp.2	Washer	Rondelle	Unterlegscheibe	
38	00323R0140	1	1	—	—	Dado M.22x1,5 H.10	Nut	Ecrou	Mutter	
39	00956R0420	—	—	2	2	Valvola getto completa	Valve	Soupape	Ventil	
40	0040550450	1	1	1	1	Fune avviamento	Starting rope	Corde	Seil	
42	0097300120	3	3	—	—	Vite M.6 x 20 TCEI	Screw	Vis	Schraube	
	0097300150	—	—	3	3	Vite M.6 x 30	Screw	Vis	Schraube	

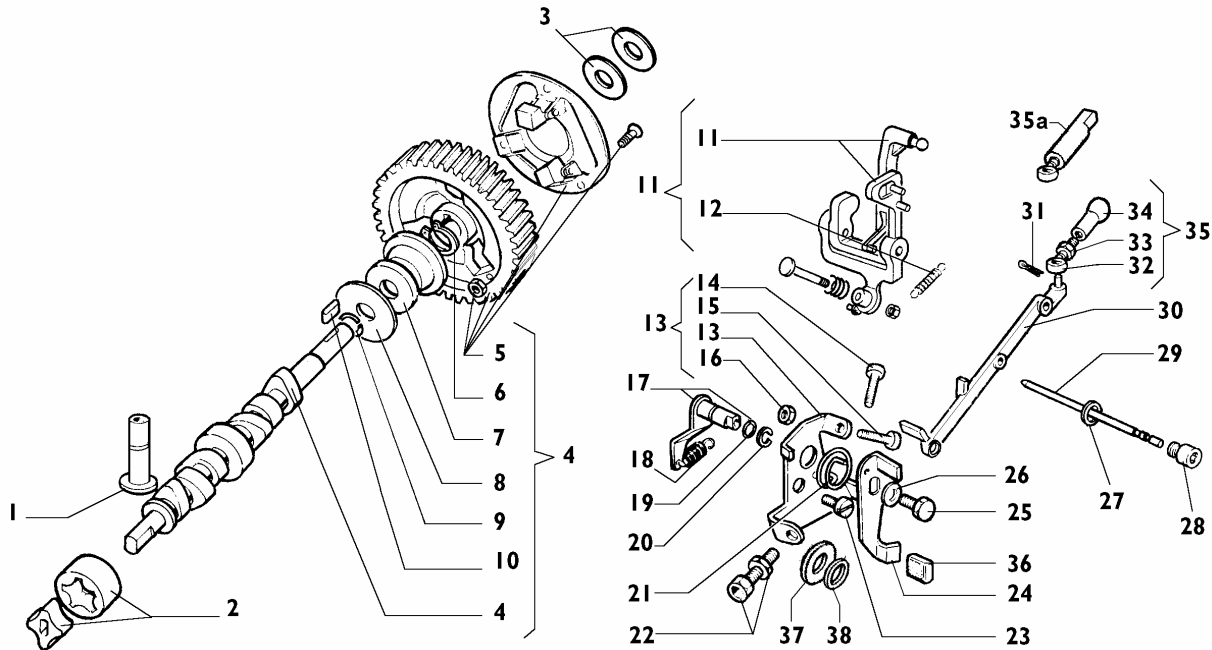

Nr. No.	CODE	MD	MD	MD	MD	DENOMINAZIONE - DESCRIPTION - DENOMINATION - BENENNUNG	CT No		
		150 Q.ty	151 Q.ty	190 Q.ty	191 Q.ty				
1	00708R0190	4	4	4	4	Punteria	Tappet	Poussoir	Stössel
2	00A21R0430	1	1	1	1	Pompa olio completa	Lub. oil pump	Pompe huile	Schmierölpumpe
3	00777R0330	1	1	1	1	Rondella rasamento 0,3 mm	Washer	Rondelle	Unterlegscheibe
	00777R0340	1	1	1	1	Rondella rasamento 0,2 mm	Washer	Rondelle	Unterlegscheibe
4	00A21R0370	1	1	—	—	Albero a camme	Camshaft	Arbre Cames	Nockenwelle
	00A23R0020	—	—	1	1	Albero a camme	Camshaft	Arbre Cames	Nockenwelle
5	00469R0810	1	1	1	1	Ingranaggio albero a camme	Gear	Engrenage	Zahnrad
6	0012400130	1	1	1	1	Anello seeger	Snap ring	Circlip	Sicherungsring
7	00621R0220	1	1	1	1	Piattello regolatore	Retainer	Coupelle	Federteller
8	00777R0780	1	1	1	1	Rondella rasamento	Washer	Rondelle	Unterlegscheibe
9	00059R0850	1	1	1	1	Anello arresto	Ring	Bague	Ring
10	00498R0360	1	1	1	1	Linguetta 4x4x12	Tab	Languette	Federkeil
11	0052021060	1	1	1	1	Leva regolatore	Lever	Levier	Hebel
	00495R0150	1	1	1	1	Leva regolatore	Lever	Levier	Hebel
12	00551R0140	1	1	1	1	Molla supplemento	Spring	Ressort	Feder
13	00613R0910	1	1	1	1	Piastrina fine corsa	Safety plate	Support	Sicherungsblech
14	—	—	—	—	—	-Non disponibile-	-Not available-	-Ne pas disponible-	-Nicht vorrätig-
15	—	—	—	—	—	-Non disponibile-	-Not available-	-Ne pas disponible-	-Nicht vorrätig-
16	0032400040	2	2	2	2	Dado M.5	Nut	Ecrou	Mutter
17	00491R0660	1	1	1	1	Leva interna acceleratore	Lever	Levier	Hebel
18	00551R0290	1	1	1	1	Molla regolatore	Spring	Ressort	Feder
19	00579R0010	1	1	1	1	Anello OR d.8.73 sez.1,78	O-ring	Joint torique	O-Ring
20	0011650360	1	1	1	1	Anello benzina D 8	Ring	Bague	Ring
21	00547R0230	1	1	1	1	Molla richiamo leva acceleratore	Spring	Ressort	Feder
22	0091801930	1	1	1	1	Registro L.20	Setscrew	Vis réglage	Einstellschraube
23	0017700010	1	1	1	1	Vite M.8x12	Screw	Vis	Schraube
24	00494R0690	1	1	1	1	Leva esterna acceleratore	Lever	Levier	Hebel
25	0017600010	1	1	1	1	Bullone M 6 x 1 x 10	Bolt	Boulon	Stehbolzen
26	0076260510	1	1	1	1	Rondella piana D.6,5x22 sp.2,5	Washer	Rondelle	Unterlegscheibe
27	0046700590	1	1	1	1	Guarnizione in rame d.10	Copper gasket	Joint en cuivre	Kupferdichtung
28	00989R0620	1	1	1	1	Vite	Screw	Vis	Schraube

250008R



REGOLATORE DI GIRI - GOVERNOR
REGULATEUR DE TOURS - REGLER

CATALOGO RICAMBI
SPARE PARTS
TAVOLA
TABLE 3 2
DATA
DATE 10/2007

Nr. No.	CODE	MD 150 Q.ty	MD 151 Q.ty	MD 190 Q.ty	MD 191 Q.ty	DENOMINAZIONE - DESCRIPTION - DENOMINATION - BENENNUNG				CT No
29	00601R0770	1	1	1	1	Perno leva regolatore	Journal	Axe	Zapfen	
30	00927R0140	1	1	1	1	Tirante collegamento pompe i.	Tie rod	Entretoise	Zugstange	
31	00555R0370	4	4	4	4	Molla di fermo tirante pompe i.	Spring	Ressort	Feder	
32	00722R0180	1	1	1	1	Registro su tirante pompe i.	Setscrew	Vis réglage	Einstellschraube	
33	0032400040	1	1	1	1	Dado M.5	Nut	Ecrou	Mutter	
34	00833R0020	1	1	1	1	Snodo sferico femmina	Joint	Rotule	Gelenk	
35	00927R0030	1	1	1	1	Tirante pompe Iniez. completo	Tie rod	Entretoise	Zugstange	
35a	00833R0100	1	1	1	1	Tirante pompe Iniez. completo	Tie rod	Entretoise	Zugstange	
36	0021350560	1	1	1	1	Cappello	Cap	Capuchon	Schutzkappe	
37	0057150250	2	2	2	2	Molla	Spring	Ressort	Feder	
38	00777R0040	7	7	7	7	Rondella ras.leva alzavalvola	Washer	Rondelle	Unterlegscheibe	

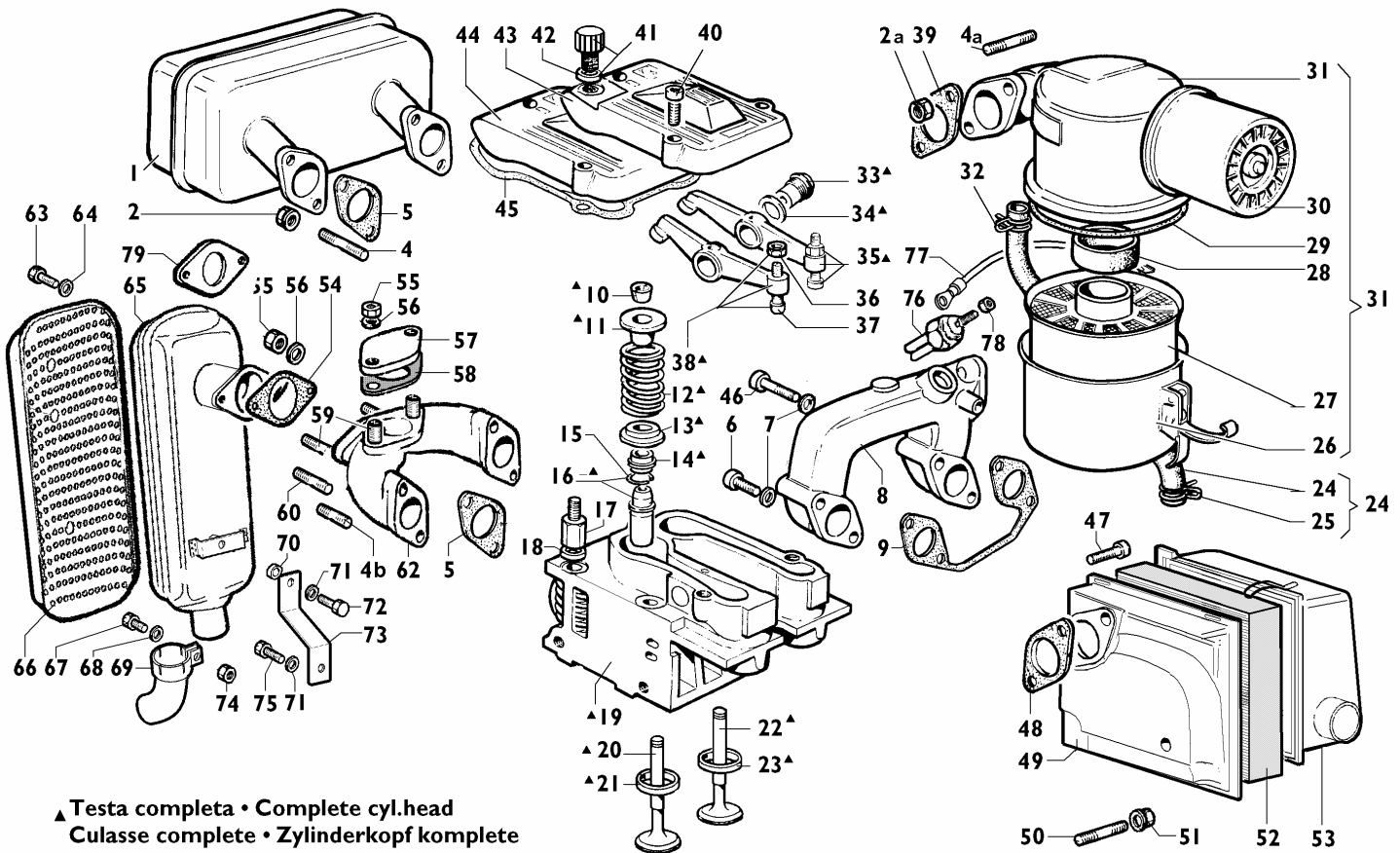

▲ Testa completa • Complete cyl.head
Culasse complete • Zylinderkopf komplette

Nr. No.	CODE	MD	MD	MD	MD	DENOMINAZIONE - DESCRIPTION - DENOMINATION - BENENNUNG	CT No
		150 Q.ty	151 Q.ty	190 Q.ty	191 Q.ty		
1	0054620990	1	1	1	1	Marmitta Muffler Pot échappement Auspufftopf	
2	0032401650	4	4	4	4	Dado M.8 Nut Ecrou Mutter	
2a	0032400210	2	2	2	2	Dado speciale M.8 ch.12 Nut Ecrou Mutter	
4	0067801590	4	4	4	4	Prigioniero M.8x18 Stud Goujon Stiftschraube	
4a	0067801590	2	2	2	2	Prigioniero M.8x18 Stud Goujon Stiftschraube	
4b	0067801590	—	—	2	2	Prigioniero M.8x18 Stud Goujon Stiftschraube	
5	00451R0240	2	2	2	2	Guarnizione scarico Gasket Joint Dichtung	
6	0097320630	2	2	2	2	Vite M.8x35 Screw Vis Schraube	
7	00771R0110	4	4	4	4	Rondella piana D.8,4x15 sp.1,5 Washer Rondelle Unterlegscheibe	
8	00211R0590	1	1	1	1	Collettore aspirazione Intake Manifold Collecteur Adm. Ansaugsammelrohr	
	00211R0630	1	1	1	1	Collettore aspiraz.per candele Inlet m.for glow plug Collecteur admiss.bougie Ansaugsammelrohr	
9	0044200780	1	1	1	1	Guarnizione aspirazione Gasket Joint Dichtung	
10	00809R0040	8	8	8	8	Semicono Cotter Semi-cône Ventilkegelstück	
11	00616R0430	4	4	4	4	Piattello superiore valvola Retainer Coupelle Federteller	
12	00540R0770	4	4	4	4	Molla valvola Spring Ressort Feder	
13	00616R0350	4	4	4	4	Piattello inferiore valvola Retainer Coupelle Federteller	
14	0045350150	4	4	4	4	Guarnizione stelo valv.asp. Gasket Joint Dichtung	
15	00059R0680	4	4	4	4	Anello guida valvola Ring Bague Ring	
16	00464R0740	4	4	4	4	Guida Valvole Valve Guide Guide Soupape Ventilführung	250005R
	00464R0590	4	4	4	4	Guida valvola asp/scar + 0.1 Valve Guide Guide Soupape Ventilführung	
17	00326R0410	1	1	1	1	Dado testa Nut Ecrou Mutter	
18	00772R0020	8	8	8	8	Rondella piana D.9,5x17 sp.4 Washer Rondelle Unterlegscheibe	
19	00A21R0390	2	2	—	—	Testa motore completa Complete cylinder head Culasse complète Zylinderkopf komplette	
	00A21R0380	2	2	—	—	Testa motore con guide Cylinder head with guides Culasse avec guide Zylinderkopf Führung	
	0092011150	—	—	2	2	Testa completa Complete cylinder head Culasse complète Zylinderkopf Komplete	250005R+ 250006R
	0092011190	—	—	2	2	Testa completa pred.candel. Complete cylinder head Culasse complète Zylinderkopf Komplete	250005R+ 250006R
	0092011170	—	—	2	2	Testa completa con decomp. Complete cylinder head Culasse complète Zylinderkopf Komplete	250005R+ 250006R
	0092011210	—	—	2	2	Testa completa pred.decomp.e candel. Complete cylinder head Culasse complète Zylinderkopf Komplete	250005R+ 250006R



**TESTA - CYLINDER HEAD
CULASSE - ZYLINDERKOPF**

CATALOGO RICAMBI
SPARE PARTS
TAVOLA
TABLE 4 2
DATA
DATE 10/2007

Nr. No.	CODE	MD 150 Q.ty	MD 151 Q.ty	MD 190 Q.ty	MD 191 Q.ty	DENOMINAZIONE - DESCRIPTION - DENOMINATION - BENENNUNG				CT No
20	00960R0540	2	2	—	—	Valvola scarico	Exhaust valve	Soupape échappement	Auslassventil	
	00960R0890	—	—	2	2	Valvola scarico	Exhaust valve	Soupape échappement	Auslassventil	250005R
21	00059R0870	2	2	—	—	Anello valvola scarico	Ring	Bague	Ring	
	00060R0940	—	—	2	2	Anello valvola scarico	Snap Ring	Circlip	Sicherungsring	250005R
22	00960R0530	2	2	—	—	Valvola aspirazione	Valve	Soupape	Ventil	
	00960R0880	—	—	2	2	Valvola aspirazione	Inlet valve	Soupape admission	Einlassventil	250005R
23	00059R0880	2	2	—	—	Anello valvola aspir.	Ring	Bague	Ring	
	00060R0950	—	—	2	2	Anello valvola aspirazione	Snap Ring	Circlip	Sicherungsring	250005R
24	00949R0510	1	1	1	1	Tubo sfiato	Oil pipe	Tuyau huile	Ölleitung	
25	00375R0510	1	1	1	1	Fascetta	Clamp	Collier	Rohrschelle	
26	—	—	—	—	—	-Non disponibile-	-Not available-	-Ne pas disponible-	-Nicht vorrätig-	
27	00359R0290	1	1	—	—	Elemento filtrante	Filter Element	Element Filtrant	Filtereinsatz	
	00359R0300	—	—	1	1	Elemento filtrante	Filter element	Element filtrant	Filtereinsatz	
28	00451R0060	1	1	1	1	Guarnizione	Gasket	Joint	Dichtung	
29	00579R0730	1	1	1	1	Anello OR	O-ring	Joint torique	O-Ring	
30	00670R0140	1	1	1	1	Prefiltro ciclone	Prefilter	Préfiltre	Vorfilter	
31	00388R0480	1	1	—	—	Filtro aria	Air Cleaner	Filtre Air	Luftfilter	
	00389R0220	—	—	1	1	Filtro aria	Air Cleaner	Filtre Air	Luftfilter	
32	0036301780	1	1	1	1	Fascetta	Clamp	Collier	Rohrschelle	
33	00602R0030	4	4	4	4	Perno bilancieri	Journal	Axe	Zapfen	
34	00754R0340	4	4	4	4	Rondella rame D.18,2x24 sp.1	Washer	Rondelle	Unterlegscheibe	
35	00104R0390	2	2	2	2	Bilanciere aspirazione	Rocker Arm	Culbuteur	Kipphebel	
	00104R0440	2	2	2	2	Bilanciere aspiraz. per decompr.	Rocker Arm	Culbuteur	Kipphebel	
36	00323R0070	4	4	4	4	Dado M.6 h.6	Nut	Écrou	Mutter	
37	00726R0030	4	4	4	4	Registro bilancieri	Setscrew	Vis réglage	Einstellschraube	
38	00104R0400	2	2	2	2	Bilanciere scarico	Rocker Arm	Culbuteur	Kipphebel	
39	00450R0350	1	1	1	1	Guarnizione asp.scarico	Gasket	Joint	Dichtung	
40	0097320780	6	6	6	6	Vite M6x25	Screw	Vis	Schraube	
41	0090320950	1	1	1	1	Tappo carico olio	Threaded plug	Bouchon fileté	Verschlußschraube	
42	00758R0390	1	1	1	1	Rondella in gomma D.22 x 27 sp.2	Washer	Rondelle	Unterlegscheibe	
43	00233R0840	1	1	1	1	Coperchio bil.con carico olio	Cover	Couvercle	Deckel	
44	00233R0820	1	1	1	1	Coperchio bilancieri	Cover	Couvercle	Deckel	
45	0044000870	2	2	2	2	Guarnizione cop.bilancieri	Gasket	Joint	Dichtung	
46	0097300340	2	2	2	2	Vite M.8x55	Screw	Vis	Schraube	
47	0097320640	2	2	2	2	Vite M.8 x 30	Screw	Vis	Schraube	
48	00450R0350	1	1	1	1	Guarnizione asp.scarico	Gasket	Joint	Dichtung	
49	00268R0290	1	1	1	1	Corpo filtro aria	Filter housing	Filtre Air	Luftfilter	
50	0067800190	2	2	2	2	Prigioniero M.8 x 30	Stud	Goujon	Stiftschraube	
51	0032401650	1	1	1	1	Dado M.8	Nut	Écrou	Mutter	
52	0021752440	1	1	1	1	Cartuccia filtro aria	Filter Element	Cartouche Filtrante	Filtereinsatz	
53	0026051100	1	1	1	1	Coperchio filtro aria	Cover	Couvercle	Deckel	
54	0045011180	1	1	1	1	Guarnizione scarico	Gasket	Joint	Dichtung	
55	0032401630	8	8	8	8	Dado M 8	Nut	Écrou	Mutter	
57	00399R0750	1	1	1	1	Flangia chiusura	Flange	Bride	Flansch	
58	00450R0350	1	1	1	1	Guarnizione asp.scarico	Gasket	Joint	Dichtung	
59	0067800850	4	4	4	4	Prigioniero M 8 X 35 (47)	Stud	Goujon	Stehbolzen	
60	0067800080	2	2	2	2	Prigioniero M.8 x 20	Stud	Goujon	Stiftschraube	
62	0024864480	1	1	1	1	Collettore scarico	Exhaust manifold	Collecteur échapp.	Auspuffsammelrohr	
63	0017700420	3	3	3	3	Vite TE M8x10	Screw	Vis	Schraube	
64	0075650070	3	3	3	3	Rondella diam. 8	Washer	Rondelle	Scheibe	
65	0054602910	1	1	1	1	Marmitta vert.inclinata distribuz.	Muffler	Pot d'échapp.	Schalldämpfer	
66	0069271720	1	1	1	1	Protezione marmitta Lafranconi	Cover	Couvercle	Deckel	
67	0017700040	1	1	1	1	Vite M8	Screw	Vis	Schraube	
68	0075650070	1	1	1	1	Rondella diam. 8	Washer	Rondelle	Scheibe	
69	0091700520	1	1	1	1	Terminale marmitta	Exhaust manifold	Collecteur ech.	Auspuffsammelrohr	
70	00356R0150	1	1	1	1	Distanziale	Spacer	Entretoise	Distanzstück	
71	0076250120	2	2	2	2	Rondella	Washer	Rondelle	Unterlegscheibe	
72	0017700040	1	1	1	1	Vite M8	Screw	Vis	Schraube	
73	00859R0620	1	1	1	1	Staffa supp. marmitta	Brace	Etrier	Bügel	
74	00323R0030	1	1	1	1	Dado M.8 H.8	Nut	Écrou	Mutter	
75	0017700090	1	1	1	1	Vite vte M.8x35	Screw	Vis	Schraube	
76	0021000550	1	1	1	1	Candeletta prerisc	Preheating glow plug	Bougie	Glühkerze	
77	0021858670	1	1	1	1	Cavo candelette	Glow plug wire	Câble bougie	Glühkerzenkabel	
78	0032400040	1	1	1	1	Dado M.5	Nut	Écrou	Mutter	
79	0038151080	1	1	1	1	Flangia scarico	Exhaust flange	Bride d'échappement	Auslassflansch	

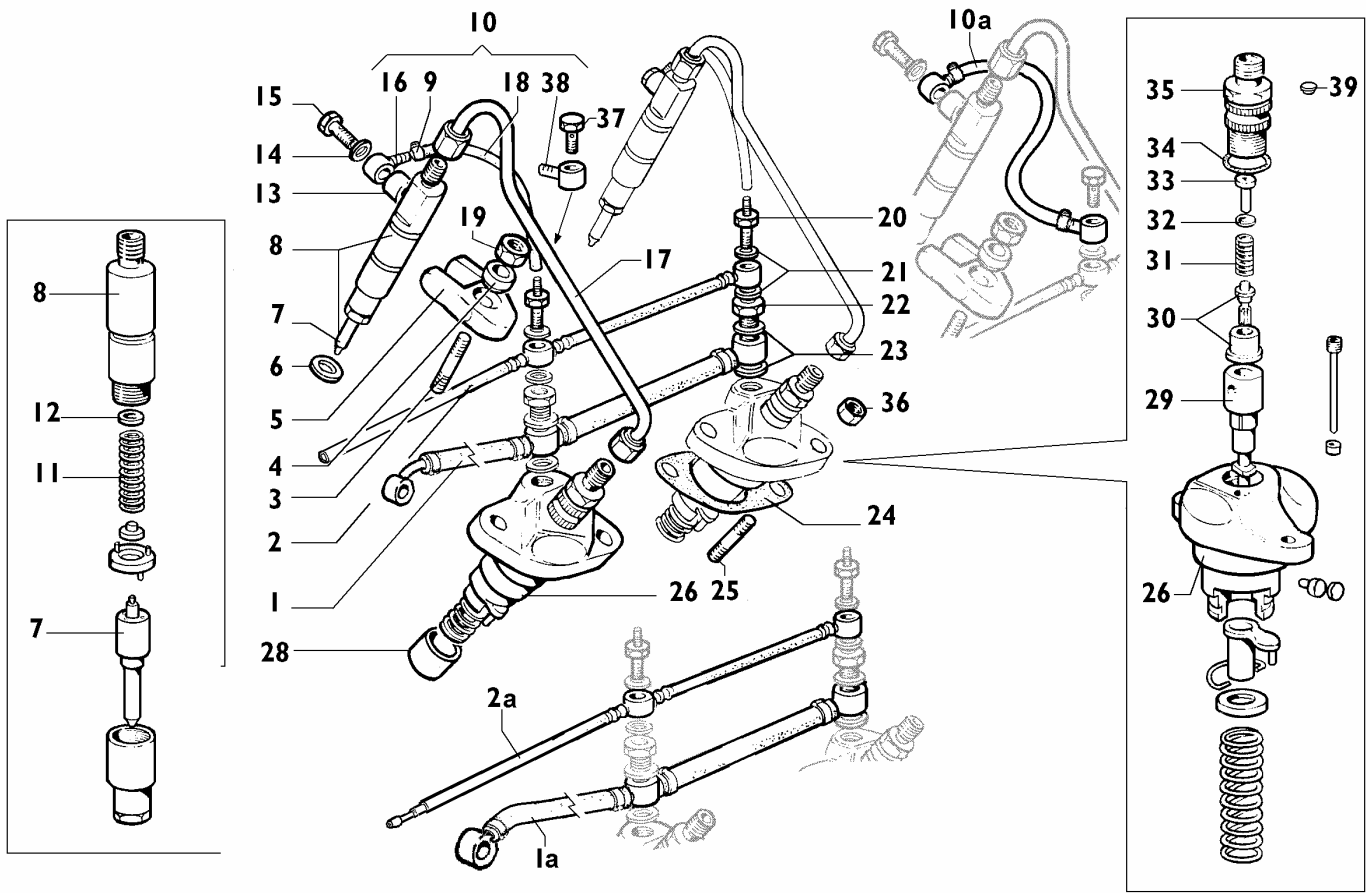

Nr. No.	CODE	MD	MD	MD	MD	DENOMINAZIONE - DESCRIPTION - DENOMINATION - BENENNUNG	CT No
		150 Q.ty	151 Q.ty	190 Q.ty	191 Q.ty		
1	00937R0460	1	1	1	1	Tubo nafta p.a.c. - p.iniezione Fuel pipe Tube combustible Brennstoffleitung	
1a	00937R0470	1	1	1	1	Tubo filtro comb. - p.iniezione Fuel pipe Tube combustible Brennstoffleitung	
2	00937R0370	1	1	—	—	Tubo disareazione p.in.-serb. Fuel pipe Tube combustible Brennstoffleitung	
	00938R0230	—	—	1	1	Tubo disareazione p.in.-serb. Deareation pipe Tube combustible Brennstoffleitung	
2a	00938R0240	1	1	1	1	Tubo disareazione p.in.-serb. Deareation pipe Tube combustible Brennstoffleitung	
3	00676R0880	2	2	2	2	Prigioniero M.8x32 r.15/12/20 Stud Goujon Stiftschraube	
4	00771R0970	2	2	2	2	Rondella D.8,4x15 sp.7,5 Washer Rondelle Unterlegscheibe	
5	00858R0940	2	2	2	2	Staffa iniettore Brace Etrier Bügel	
6	00754R0350	2	2	2	2	Rondella rame D.7,25x21 sp.1 Washer Rondelle Unterlegscheibe	
	00754R0510	2	2	2	2	Rondella rame D.7.25x21 sp.0,5 Washer Rondelle Unterlegscheibe	
7	00644R0680	2	2	2	2	Polverizzatore STANADYNE Nozzle Injecteur Einspritzdüse	
8	00644R0560	2	2	2	2	Polverizzatore completo BOSCH Nozzle Injecteur Einspritzdüse	
	00644R0610	2	2	2	2	Polverizzatore completo STANADYNE Nozzle Injecteur Einspritzdüse	
9	0036300500	4	4	4	4	Fascetta oteco clic 55 Clamp Collier Schelle	250007R
10	00A23R0220	—	—	2	2	Tubo rifiuto iniettore completo Fuel pipe Tube combustible Brennstoffleitung	250007R
10a	0095712520	2	2	2	2	Tubo rifiuto iniettore Fuel pipe Tube combustible Brennstoffleitung	250007R
11	00540R0790	2	2	2	2	Molla Spring Ressort Feder	
12	00837R0300	2	2	2	2	Rondella taratura 0,1 mm Shim Cale Unterlegscheibe	
	00837R0350	2	2	2	2	Spessore di taratura 1 mm Shim Cale Unterlegscheibe	
13	00754R0500	2	2	2	2	Rondella rame D.6,2x10 sp.2,5 Washer Rondelle Unterlegscheibe	
14	0046700620	2	2	2	2	Rondella rame D.6,2x10 sp.1,5 Washer Rondelle Unterlegscheibe	
15	0072600530	2	2	2	2	Raccordo Union Raccord Anschlußstück	
16	0072702370	2	2	2	2	Raccordo d. 6 Banjo union Raccord Ringanschluss	250007R
17	00944R0670	2	2	—	—	Tubo iniezione Fuel pipe Tube combustible Brennstoffleitung	
	00944R0680	—	—	2	2	Tubo iniezione Fuel pipe Tube combustible Brennstoffleitung	
18	0093758390	2	2	—	—	Tubo rifiuto iniettore Fuel pipe Tube combustible Brennstoffleitung	250007R
	0093759150	—	—	2	2	Tubo rifiuto iniettore Fuel pipe Tube combustible Brennstoffleitung	250007R
19	00323R0030	2	2	2	2	Dado M.8 H.8 Nut Ecrou Mutter	
20	00717R0540	2	2	—	—	Raccordo disareazione Union Raccord Anschlußstück	250007R
21	0046700580	4	4	4	4	Rondella rame D.8,2x12 sp.1 Washer Rondelle Unterlegscheibe	
22	0019010120	2	2	2	2	Raccordo completo disareazione Union Raccord Anschlußstück	
23	0046700600	4	4	4	4	Rondella rame D.12,2x16 sp.1,5 Washer Rondelle Unterlegscheibe	



POMPA INIEZIONE E INIETTORE - INJECTION PUMP AND INJECTOR
POMPE A INJECTION-PORTE INJECTEUR - EINSPRITZPUMPE UND EINSPRITZDÜSE

CATALOGO RICAMBI
SPARE PARTS

TAVOLA
TABLE

5 2

DATA
DATE

10/2007

Nr. No.	CODE	MD	MD	MD	MD	DENOMINAZIONE - DESCRIPTION - DENOMINATION - BENENNUNG	CT No
		150 Q.ty	151 Q.ty	190 Q.ty	191 Q.ty		
24	00450R0650	2	2	2	2	Guarnizione pompa in. 0,3 mm Gasket Joint Dichtung	250007R
	00450R0660	2	2	2	2	Guarnizione pompa in. 0,2 mm Gasket Joint Dichtung	
	00450R0670	2	2	2	2	Guarnizione pompa in. 0,1 mm Gasket Joint Dichtung	
25	0067800680	2	2	2	2	Prigioniero M 8 X 18 (30) Stud Goujon Stehbolzen	
26	00656R0600	2	2	2	2	Pompa iniezione STANADYNE Injection pump Pompe injection Einspritzpumpe	
28	0072150350	2	2	2	2	Punteria pompa iniezione Tappet Poussoir Stössel	
29	00660R0240	2	2	2	2	Pompante STANADYNE Pumping element Element pompe Pumpelement	
30	00956R0430	2	2	2	2	Valvola STANADYNE Valve Soupape Ventil	
31	0057550340	2	2	2	2	Molla valvola mandata Valve spring Ressort soupape Ventilfeder	
32	0083350290	2	2	2	2	Spessore Washer seal Rondelle d'étanchéité Scheibe	
33	0074700030	2	2	2	2	Riempitore Union Raccord Anschlußstück	
34	0012002790	3	3	3	3	Anello OR d.15.60 sez.1,78 O-ring Joint torique O-Ring	
35	0072650080	2	2	2	2	Raccordo Connection Raccord Druckventilhalter	
36	0032030990	4	4	4	4	Dado autobloccante M.8 H.7,9 Nut Ecrou Mutter	
37	00716R0170	—	—	2	2	Raccordo 8x1x25 Union Raccord Anschlußstück	
38	00575R0300	—	—	2	2	Occhiello D.8,25 Eye Oeillet Öse	
39	00738R0100	2	2	2	2	Tappo per pompa Plug Bouchon Verschuß	

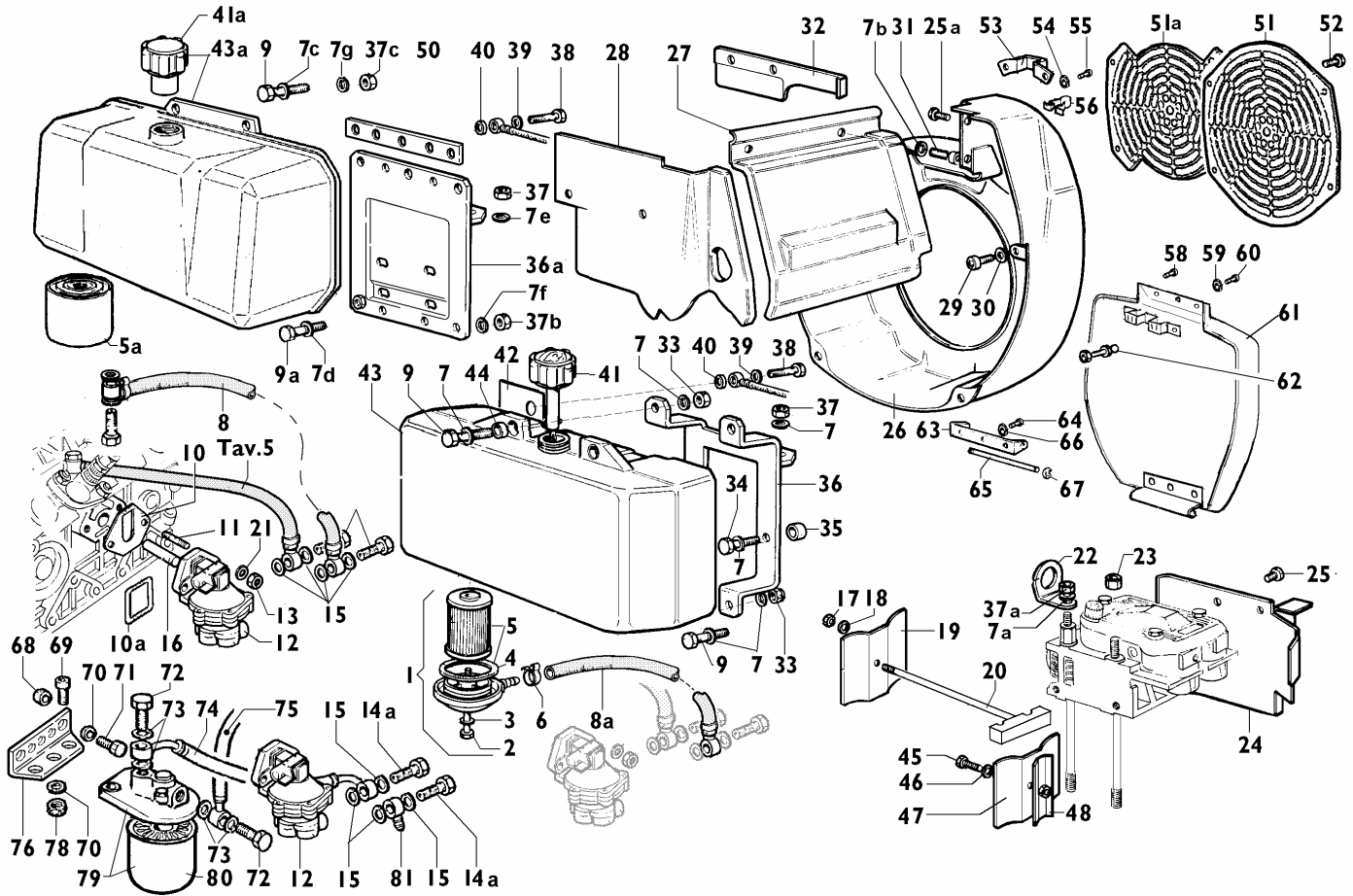

Nr. No.	CODE	MD 150 Q.ty	MD 151 Q.ty	MD 190 Q.ty	MD 191 Q.ty	DENOMINAZIONE - DESCRIPTION - DENOMINATION - BENENNUNG				CT No
1	00391R0450	1	1	1	1	Filtro nafta interno completo	Fuel Filter	Filtre Combustible	Brennstofffilter	
2	0017600610	1	1	1	1	Vite	Screw	Vis	Schraube	
3	00754R0320	1	1	1	1	Rondella	Washer	Rondelle	Unterlegscheibe	
4	00450R0970	1	1	1	1	Guarnizione	Gasket	Joint	Dichtung	
5	0021752050	1	1	1	1	Cartuccia gasolio	Filter Element	Cartouche Filtrante	Filtereinsatz	
5a	0021752000	1	1	1	1	Cartuccia nafta	Filter element	Cartouche filtrante	Filtereinsatz	
6	0036300080	1	1	1	1	Fascetta stringitubo	Clamp	Collier	Rohrschelle	
7	0076250120	12	12	12	12	Rondella	Washer	Rondelle	Unterlegscheibe	
7a	0076250120	1	1	1	1	Rondella	Washer	Rondelle	Unterlegscheibe	
7b	0076250120	2	2	2	2	Rondella	Washer	Rondelle	Unterlegscheibe	
7c	0076250120	2	2	2	2	Rondella	Washer	Rondelle	Unterlegscheibe	
7d	0076250120	2	2	2	2	Rondella	Washer	Rondelle	Unterlegscheibe	
7e	0076250120	2	2	2	2	Rondella	Washer	Rondelle	Unterlegscheibe	
7f	0076250120	2	2	2	2	Rondella	Washer	Rondelle	Unterlegscheibe	
7g	0076250120	2	2	2	2	Rondella	Washer	Rondelle	Unterlegscheibe	
8	0093740220	1	1	1	1	Tubo nafta da serbat.a pompa ac	Pipe	Tuyau	Rohr	
8a	00937R0320	1	1	1	1	Tubo pm.al.-ft. (mm 500)	Fuel hose	Tube combustible	Brennstoffleitung	
9	0017700040	4	4	4	4	Vite M8	Screw	Vis	Schraube	
9a	0017700060	2	2	2	2	Vite M.8x25	Screw	Vis	Schraube	
10a	0012000870	1	1	1	1	Guarnizione p.a.c.	Gasket	Joint	Dichtung	250004R
11	0067800490	2	2	2	2	Prigioniero asp. M 8 X 20 (36)	Stud	Goujon	Stehbolzen	
12	0065850970	1	1	1	1	Pompa A.C.	Fuel feeding pump	Pompe d'alimentation	Kraftstoffpumpe	250004R
13	0032401640	2	2	2	2	Dado autob. M8	Nut	Ecrou	Mutter	
14a	0019010300	2	2	2	2	Bullone raccordo M 10	Union bolt	Boulon raccord	Hohlschraube	
15	0046700590	4	4	4	4	Guarnizione in rame d.10	Copper gasket	Joint en cuivre	Kupferdichtung	
16	00704R0130	1	1	1	1	Puntalino pompa a.c.	Drive rod	Butée	Betätigungsstange	
17	0032030770	—	—	1	1	Dado autobloccante M.4 H.5,8	Nut	Ecrou	Mutter	
18	0076250520	—	—	1	1	Rondella piana D.4,3x9 sp.0,8	Washer	Rondelle	Unterlegscheibe	
19	00589R0200	—	—	1	1	Paratia esterna cilindri	Gate	Cloison	Schott	
20	00926R0780	—	—	1	1	Tirante paratie	Tie rod	Entretoise	Zugstange	
21	0075550290	2	2	2	2	Rondella	Washer	Rondelle	Scheibe	
22	0085060030	2	2	2	2	Golfare	Engine lifting eye	Équerre	Befestigungswinkel	



RAFFREDDAMENTO - COOLING
REFROIDISSEMENT - LUFTKÜHLUNG

CATALOGO RICAMBI
SPARE PARTS
TAVOLA
TABLE **6 2**
DATA
DATE **10/2007**

Nr. No.	CODE	MD 150 Q.ty	MD 151 Q.ty	MD 190 Q.ty	MD 191 Q.ty	DENOMINAZIONE - DESCRIPTION - DENOMINATION - BENENNUNG	CT No
23	00326R0380	7	7	7	7	Dado testa Nut Ecrou Mutter	
24	00588R0850	1	1	1	1	Paratia lato volano Gate Cloison Schott	
25	0097901380	2	2	2	2	Vite TC 6x10 5S ZN.B. Capscrew Vis Schraube	
25a	0097301070	2	2	2	2	Vite M.6x14 Screw Vis Schraube	
26	0025696770	1	1	—	—	Convogliatore STD Shroud Coiffe Ventil Ventilatorhaube	
	0025696760	—	—	1	1	Convogliatore aria Air conveyor Coiffe ventil Ventilatorhaube	
27	00297R0010	1	1	—	—	Cuffia cilindri Cylinder casing Protection cylindre Zylinderverkleidung	
	00296R0870	—	—	1	1	Cuffia cilindri Cylinder casing Protection cylindre Zylinderverkleidung	
	0029201870	—	—	1	1	Cuffia cilindri p.iniez Bosch Cylinder casing Protection cylindre Zylinderverkleidung	
28	00588R0880	1	1	—	—	Paratia lato applicazione Gate Cloison Schott	
	00589R0190	—	—	1	1	Paratia lato applicazione Gate Cloison Schott	
29	0097301070	4	4	4	4	Vite M.6x14 Screw Vis Schraube	
30	0076250080	2	2	2	2	Rondella piana D.12x6,5 Washer Rondelle Unterlegscheibe	
31	0097320740	2	2	2	2	Vite M 8 x 20 Screw Vis Schraube	
32	00589R0070	—	—	1	1	Paratia superiore Gate Cloison Schott	
33	0032030750	4	4	4	4	Dado autobloccante M.8 H.10,4 Nut Ecrou Mutter	
34	0017700890	2	2	2	2	Vite te M.8x30 Screw Vis Schraube	
35	00354R0800	2	2	2	2	Distanziale per serbatoio Spacer Entretoise Distanzstück	
36	00879R0680	1	1	1	1	Supporto serbatoio Support Support Lager	
36a	00879R0630	1	1	1	1	Supporto serbatoio Support Support Lager	
37	00323R0030	2	2	2	2	Dado M.8 H.8 Nut Ecrou Mutter	
37a	00323R0030	1	1	1	1	Dado M.8 H.8 Nut Ecrou Mutter	
37b	00323R0030	2	2	2	2	Dado M.8 H.8 Nut Ecrou Mutter	
37c	00323R0030	2	2	2	2	Dado M.8 H.8 Nut Ecrou Mutter	
38	0019011730	1	1	1	1	Raccordo 8x1x25 (8.8) foro 3 mm. Union Raccord Anschlußstück	
39	0046700580	1	1	1	1	Rondella rame D.8,2x12 sp.1 Washer Rondelle Unterlegscheibe	
40	00754R0460	1	1	1	1	Rondella rame D.8x14 sp.4 Washer Rondelle Unterlegscheibe	
41	0090430980	1	1	1	1	Tappo serbatoio Tank cap Bouchon Verschluss	
41a	00898R0210	1	1	1	1	Tappo serbatoio M.36x2 Plug Bouchon Verschluss	
42	00582R0960	1	1	1	1	Targhetta adesiva protez.serb. Advert.material Objets publicit. Werbe-Artikel	
43	0081011060	1	1	1	1	Serbatoio nafta Fuel tank Réservoir Kraftstoffbehälter	
43a	00A20R0470	1	1	1	1	Serbatoio con sede filtro Fuel tank Réservoir Kraftstoffbehälter	
44	00354R0800	2	2	2	2	Distanziale per serbatoio Spacer Entretoise Distanzstück	
45	00993R0620	1	1	—	—	Vite vte M.4x14 Screw Vis Schraube	
46	0076250520	1	1	—	—	Rondella piana D.4,3x9 sp.0,8 Washer Rondelle Unterlegscheibe	
47	00588R0930	1	1	—	—	Paratia esterna su cilindri Gate Cloison Schott	
48	00588R0860	1	1	—	—	Paratia interna su cilindri Gate Cloison Schott	
50	00379R0170	2	2	2	2	Feltro serbatoio Felt gasket Feutre Filz	
51	00689R0450	—	—	1	1	Protezione volano Guard Protection Schutz	
51a	00689R0470	—	—	1	1	Protez.amovibile copripuleggia ins. Flywheel guard Protection volant Schwungradschutz	
52	00998R0130	—	—	4	4	Vite M.6x6 Screw Vis Schraube	
53	00613R0170	1	1	—	—	Piastrina Safety plate Support Sicherungsblech	
	00613R0600	—	—	1	1	Piastrina sostegno molla Safety plate Support Sicherungsblech	
54	00772R0430	2	2	2	2	Rondella piana D.3,2x8 sp.0,8 Washer Rondelle Unterlegscheibe	
55	00738R0110	2	2	2	2	Ribattino D.3x8 Rivet Rivet Niete	
56	00555R0320	1	1	1	1	Molla copripuleggia Spring Ressort Feder	
58	00738R0110	2	2	2	2	Ribattino D.3x8 Rivet Rivet Niete	
59	00772R0360	3	3	3	3	Rondella piana d.4x12.5 sp.1,6 Washer Rondelle Unterlegscheibe	
60	00742R0180	3	3	3	3	Rivetto a strappo Rivet Rivet Niete	
61	0026700510	1	1	1	1	Copripuleggia apribile Pulley guard Protège poulie Riemenscheibenschutz	
62	00601R0730	1	1	1	1	Perno x attacco rapido Journal Axe Zapfen	
63	00879R0880	1	1	1	1	Supporto copripuleggia Support Support Lager	
64	00738R0110	5	5	5	5	Ribattino D.3x8 Rivet Rivet Niete	
65	00601R0530	1	1	1	1	Perno supporto copripuleggia Journal Axe Zapfen	
66	00772R0430	5	5	5	5	Rondella piana D.3,2x8 sp.0,8 Washer Rondelle Unterlegscheibe	
67	0011650040	2	2	2	2	Anello seeger D.5 Snap ring Circlip Sicherungsring	
68	0035260970	2	2	2	2	Distanziale D.9x13 H.16 Spacer Entretoise Distanzstück	
69	0097320640	2	2	2	2	Vite M.8 x 30 Screw Vis Schraube	
70	0076250120	4	4	4	4	Rondella Washer Rondelle Unterlegscheibe	
71	0017700090	2	2	2	2	Vite vte M.8x35 Screw Vis Schraube	
72	0019010320	2	2	2	2	Bullone raccordo M 14 Union bolt Boulon raccord Hohlschraube	
73	0046700610	4	4	4	4	Guarnizione in rame d.14 Gasket Joint Dichtung	
74	0093758540	—	—	1	1	Tubo filtro->pm.al. mm 680 Hose Tube combustible Brennstoffleitung	
76	00612R0310	1	1	1	1	Piastrina Safety plate Support Sicherungsblech	
78	00323R0030	2	2	2	2	Piastrina Safety plate Support Mutter	
79	0037301570	1	1	1	1	Piastrina Safety plate Support Kraftstofffilter	
80	0021750450	1	1	1	1	Cartuccia comb. Fuel filter cartridge Cartouche de combustible Kraftstofffiltereinsatz	
81	0072701040	—	—	1	1	Raccordo d.10 Banjo union Raccord Ringanschluss	

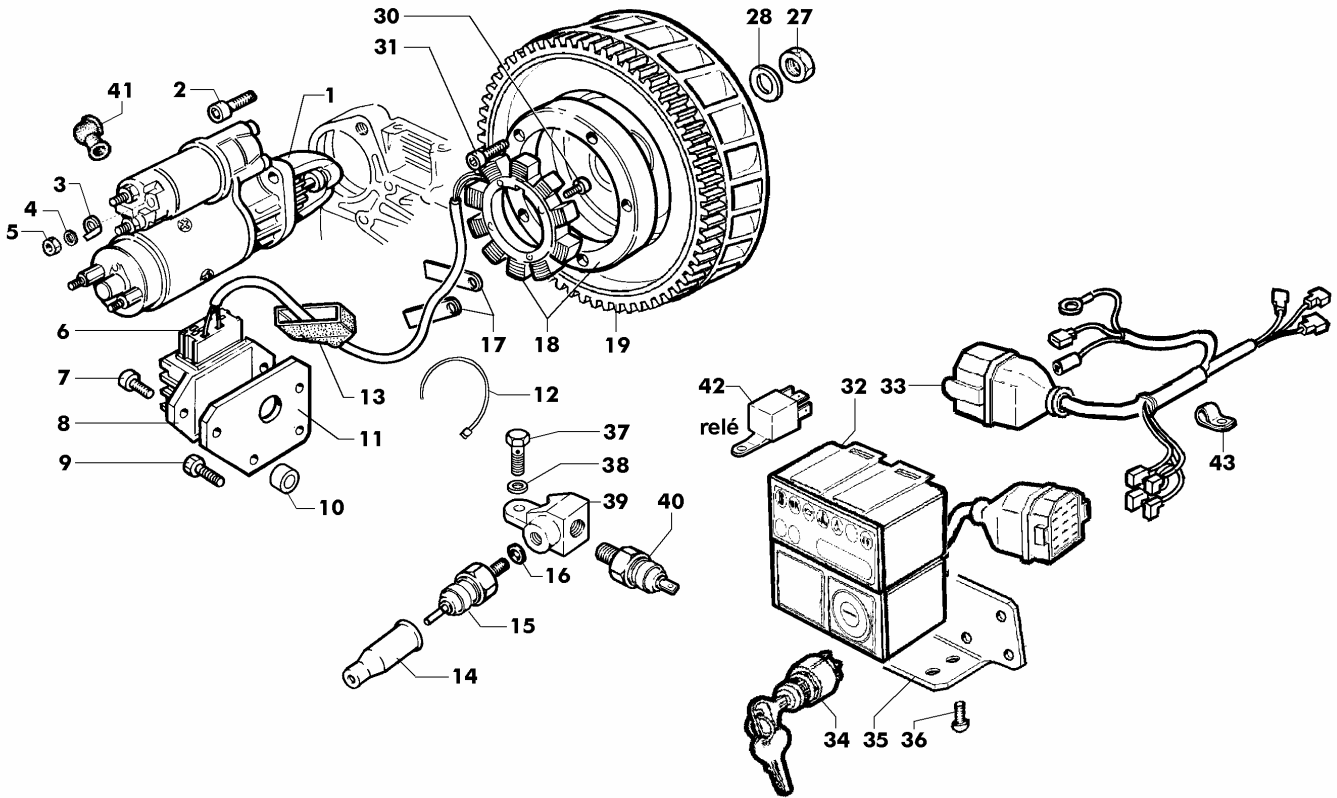

Nr. No.	CODE	MD	MD	MD	MD	DENOMINAZIONE - DESCRIPTION - DENOMINATION - BENENNUNG				CT No
		150	151	190	191					
		Q.ty	Q.ty	Q.ty	Q.ty					
1	00563R0540	1	1	1	1	Motorino avviamento BOSCH	Starting motor	Démarrreur	Anlasser	250003R
	0058402110	1	1	1	1	Motorino avviamento BOSCH 24V	Starting motor	Démarrreur	Anlasser	
2	0097303690	2	2	2	2	Vite M.10x30	Screw	Vis	Schraube	
3	0091801680	1	1	1	1	Faston	Faston	Faston	Faston	
4	00763R0020	1	1	1	1	Rondella grower d.8 rinforzata	Washer	Rondelle	Unterlegscheibe	
5	00323R0030	1	1	1	1	Dado M.8 H.8	Nut	Ecrou	Mutter	
6	0067401530	1	1	1	1	Presa regol.	Inlet regul.	Prise régulateur	Reglerstecker	
7	0097310920	2	2	2	2	Vite M.8x14	Screw	Vis	Schraube	
8	0073623510	1	1	1	1	Reg.tens.12V 20A alt. 2 fili	Voltage regulator	Régulateur de tension	Spannungsregler	
9	0017700090	2	2	2	2	Vite vte M.8x35	Screw	Vis	Schraube	
10	00353R0820	2	2	—	—	Distanziale D.9x13 H.15	Spacer	Entretoise	Distanzstück	
	0035260970	—	—	2	2	Distanziale D.9x13 H.16	Spacer	Entretoise	Distanzstück	
11	00613R0640	1	1	1	1	Piastrina	Safety plate	Support	Sicherungsblech	
12	0024710190	3	3	3	3	Fascetta	Clamp	Collier	Rohrschelle	
13	0021450140	1	1	1	1	Cappuccio regolatore	Regulator cap	Capuchon régulateur	Reglerabdeckung	
14	0064910130	1	1	1	1	Cappello	Cap	Capouchon	Schutzkappe	
15	00674R0010	1	1	1	1	Pressostato	Elettrostop	Elettrostop	Elettrostop	
16	0046700580	1	1	1	1	Rondella rame D.8,2x12 sp.1	Washer	Rondelle	Unterlegscheibe	
17	00613R0760	2	2	2	2	Piastrina ferma cavo	Safety plate	Support	Sicherungsblech	
18	0011573410	1	1	1	1	Alternatore 12V 18A	Alternator	Alternateur	Drehstrom gener.	
19	00256R0140	1	1	1	1	Corona avviamento	Ring Gear	Couronne Démarrage	Starterkranz	
27	00325R0840	1	1	1	1	Dado M.22x1,5 H.13	Nut	Ecrou	Mutter	
28	00771R0460	1	1	1	1	Rondella piana D.22,2x44 sp.7,5	Washer	Rondelle	Unterlegscheibe	
30	0017550240	4	4	4	4	Vite M5 x 20	Screw	Vis	Schraube	
31	0097303190	5	5	5	5	Vite M.6x12	Screw	Vis	Schraube	
32	0072454200	—	—	1	1	Quadr.12V 6 spie (con candel.)alt.3 fili	Dashboard	Tableau de bord	Bedienfeld	
33	0021861150	—	—	1	1	Cavi	Cables	Câbles	Kabel	
34	0050410200	—	—	1	1	Interruttore a chiave	Key switch	Interrupter à clef	Schlüsselschalter	
35	0085061300	—	—	1	1	Squadretta	Bracket	Equerre	Befestigungswinkel	
36	0097303250	—	—	4	4	Vite M 5 X 10	Screw	Vis	Schraube	
37	0019011730	—	—	1	1	Raccordo 8x1x25 (8.8) foro 3 mm.	Union	Raccord	Anschlußstück	



AVVIAMENTO ELETTRICO - ELECTRICAL STARTING
DEMARRAGE ELECTRIQUE - ELEKTRISCHER ANLASSER

CATALOGO RICAMBI
SPARE PARTS

TAVOLA
TABLE

7 2

DATA
DATE

10/2007

Nr. No.	CODE	MD 150 Q.ty	MD 151 Q.ty	MD 190 Q.ty	MD 191 Q.ty	DENOMINAZIONE - DESCRIPTION - DENOMINATION - BENENNUNG				CT No
38	0046700580	—	—	2	2	Rondella rame D.8,2x12 sp.1	Washer	Rondelle	Unterlegscheibe	
39	0073303690	—	—	1	1	Raccordo	Union	Raccord	Anschluss	
40	0050412670	—	—	1	1	Interruttore pressione olio (M 10)	Oil switch	Interrupteur pression	Druckschalter	
41	0064910050	—	—	1	1	Pipetta mot.avv.	Pipe elbow	Pipe démarreur	Schlauchbogen	
42	0073692090	—	—	1	1	Rele-centralina cand.	Preheating plug control box	Relais-boîte bougies	Relais	
43	0036170200	—	—	1	1	Fascetta	Clamp	Collier	Schelle	

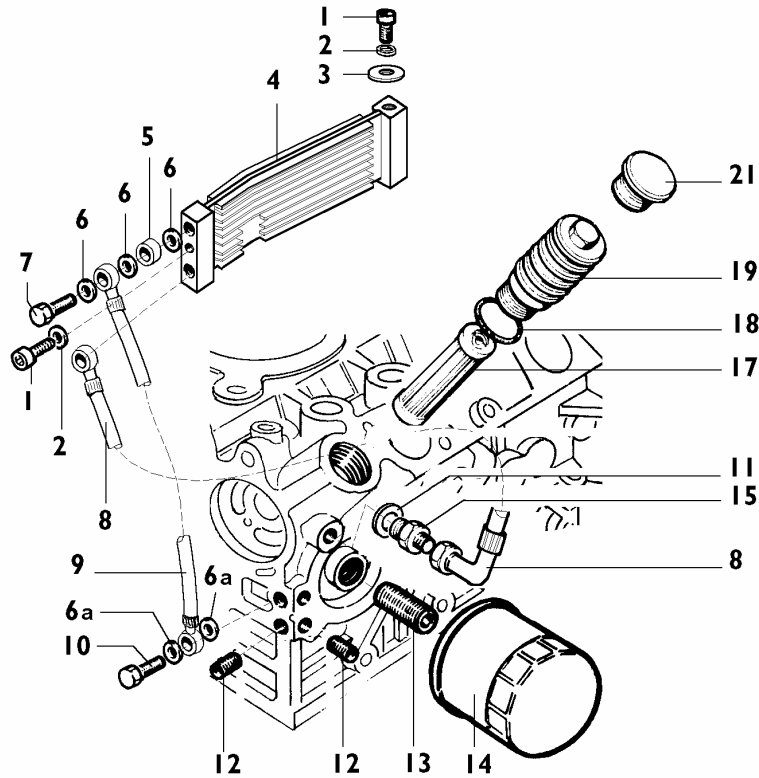

Nr. No.	CODE	MD	MD	MD	MD	DENOMINAZIONE - DESCRIPTION - DENOMINATION - BENENNUNG				CT No
		150 Q.ty	151 Q.ty	190 Q.ty	191 Q.ty					
1	0097301070	—	—	2	2	Vite M.6x14	Screw	Vis	Schraube	
2	0076250080	—	—	2	2	Rondella piana D.12x6,5	Washer	Rondelle	Unterlegscheibe	
3	0076260510	—	—	1	1	Rondella piana D.6,5x22 sp.2,5	Washer	Rondelle	Unterlegscheibe	
4	00804R0280	—	—	1	1	Radiatore olio	Radiator	Radiateur	Kühler	
5	00355R0500	—	—	2	2	Distanziale D.12,2x18 h.9	Spacer	Entretoise	Distanzstück	
6	00754R0380	—	—	4	4	Rondella rame D.13,5x19 sp.1,5	Washer	Rondelle	Unterlegscheibe	
6a	0046700600	—	—	4	4	Rondella rame D.12,2x16 sp.1,5	Washer	Rondelle	Unterlegscheibe	
7	00717R0900	—	—	2	2	Raccordo M.12x1,5x35,5	Union	Raccord	Anschlußstück	
8	00949R0400	—	—	1	1	Tubo olio mandata al radiatore	Oil pipe	Tuyau huile	Ölleitung	
9	00949R0420	—	—	1	1	Tubo olio ritorno dal radiatore	Oil pipe	Tuyau huile	Ölleitung	
10	00717R0920	—	—	1	1	Raccordo M.12x1,5x23,5	Union	Raccord	Anschlußstück	
11	0046700600	—	—	1	1	Rondella rame D.12,2x16 sp.1,5	Washer	Rondelle	Unterlegscheibe	
12	0097651110	—	—	2	2	Tappo filettato conico M.8x1x8	Threaded plug	Bouchon fileté	Verschlußschraube	
13	00717R0370	—	—	1	1	Raccordo filtro olio	Union	Raccord	Anschlußstück	
14	0021750400	—	—	1	1	Cartuccia olio D.76	Oil filter cartridge	Cartouche à huile	Ölfiltersatz	
15	00717R0910	—	—	1	1	Raccordo riduz.3/8"/M.12x1,5	Union	Raccord	Anschlußstück	
17	0021751950	1	1	—	—	Cartuccia filtro olio interna	Oil filter cartridge	Cartouche à huile	Ölfiltersatz	
18	00579R0690	1	1	—	—	Anello OR D.28,30	O-ring	Joint torique	O-Ring	
19	00894R0550	1	1	—	—	Tappo sede filtro olio	Threaded plug	Bouchon fileté	Verschlußschraube	
21	00886R0740	—	—	1	1	Tappo	Plug	Bouchon	Verschluß	

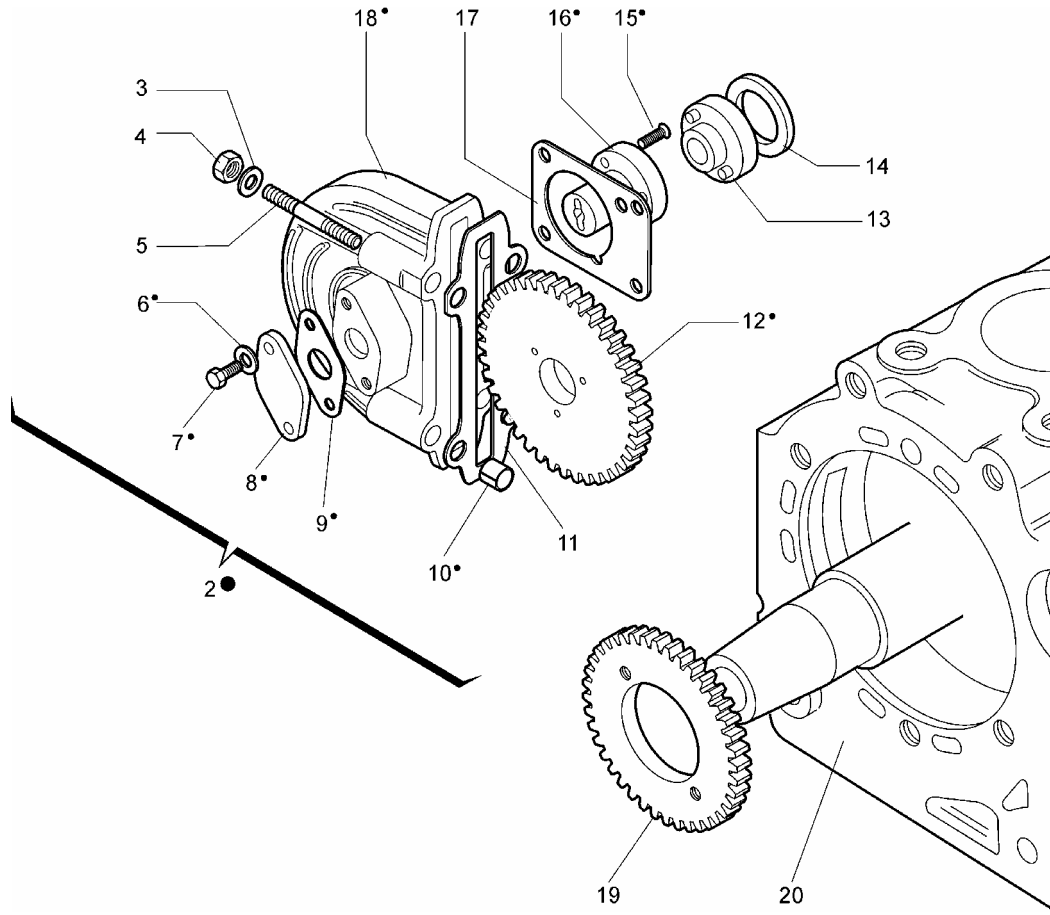

Nr. No.	CODE	MD	MD	MD	MD	DENOMINAZIONE - DESCRIPTION - DENOMINATION - BENENNUNG	CT No
		150 Q.ty	151 Q.ty	190 Q.ty	191 Q.ty		
2	00880R0950	1	1	1	1	Kit supporto pompa idraulica Support Support Lager	
3	0076250120	4	4	4	4	Rondella Washer Rondelle Unterlegscheibe	
4	00323R0030	4	4	4	4	Dado M.8 H.8 Nut Ecrou Mutter	
5	00676R0230	4	4	4	4	Prigioniero M.8x51 Stud Goujon Stiftschraube	
6	00771R0010	2	2	2	2	Rondella piana 5,3x10 Washer Rondelle Unterlegscheibe	
7	00993R0780	2	2	2	2	Vite M.5x12 Screw Vis Schraube	
8	00231R0950	1	1	1	1	Coperchio Cover Couvercle Deckel	
9	00448R0990	1	1	1	1	Guarnizione Gasket Joint Dichtung	
10	00850R0570	2	2	2	2	Spina elastica Taper pin Goupille Kegelstift	
11	00450R0870	1	1	1	1	Guarnizione Gasket Joint Dichtung	
12	00469R0680	1	1	1	1	Ingranaggio Gear Engrenage Zahnrad	
13	00814R0690	1	1	1	1	Semigiunto per GR.1 Haft coupling Demi-accooup. Kupplung	
14	00042R0020	1	1	1	1	Anello riduz. per GR.1 Ring Bague Ring	
15	00998R0040	3	3	3	3	Vite M5x20 Screw Vis Schraube	
16	00602R0310	1	1	1	1	Perno pompa idraulica Journal Axe Zapfen	
17	00448R0010	1	1	1	1	Guarnizione pompa idraulica GR.1 Gasket Joint Dichtung	
18	00880R0650	1	1	1	1	Supporto pompa idraulica Support Support Lager	
19	00469R0690	1	1	1	1	Ingranaggio compando pompa Gear Engrenage Zahnrad	
20	00A26R0270	1	1	—	—	Carter motore per pompa idraulica Crankcase Carter moteur Kurbelgehäuse	
	00A26R0830	—	—	1	1	Carter motore per pompa idraulica Crankcase Carter moteur Kurbelgehäuse	

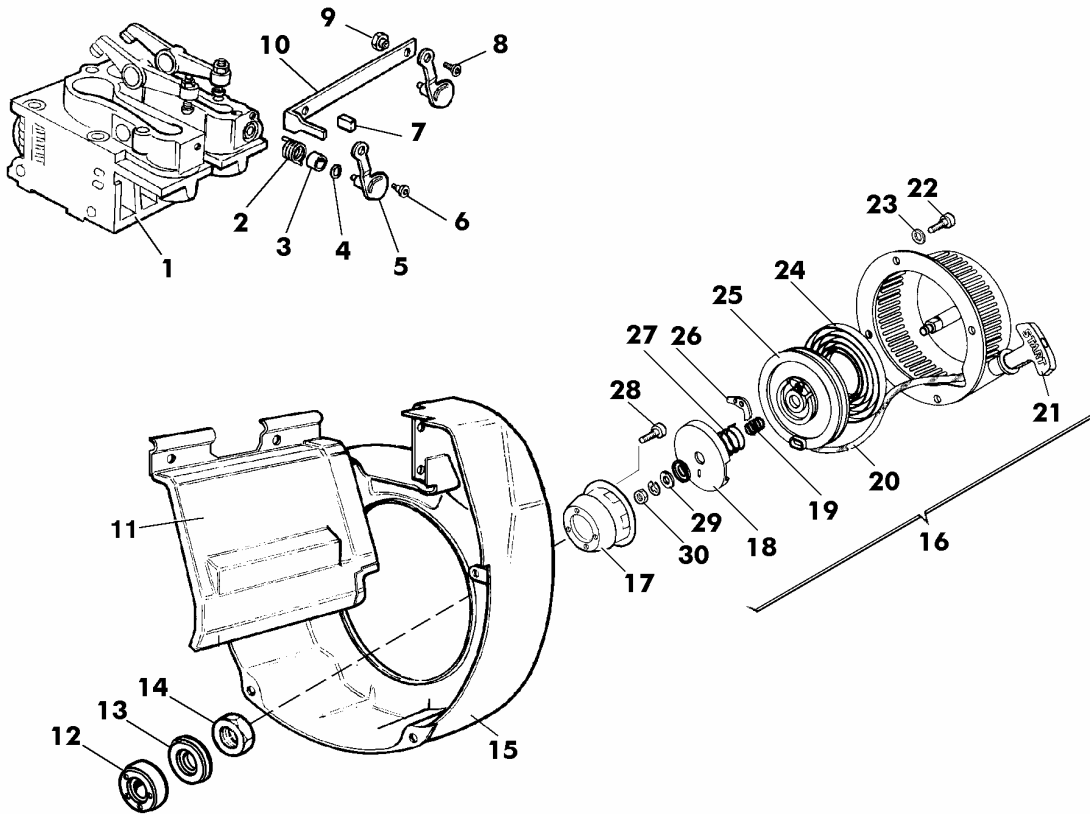

Nr. No.	CODE	MD	MD	MD	MD	DENOMINAZIONE - DESCRIPTION - DENOMINATION - BENENNUNG	CT No
		150 Q.ty	151 Q.ty	190 Q.ty	191 Q.ty		
1	00A25R0230	2	2	2	2	Testa motore completa Complete cylinder head Culasse complète Zylinderkopf Komplete	
2	00547R0760	2	2	2	2	Molla leva alzavalvola Spring Ressort Feder	
3	00355R0240	2	2	2	2	Distanziale Distanziale Entretoise Distanzstück	
4	00771R0110	2	2	2	2	Rondella piana D.8,4x15 sp.1,5 Washer Rondelle Unterlegscheibe	
5	00491R0070	2	2	2	2	Leva alzavalvola Lever Levier Hebel	
6	00994R0260	2	2	2	2	Vite M.5x18 Screw Vis Schraube	
7	0021350560	1	1	1	1	Cappello Cap Capuchon Schutzkappe	
8	00997R0650	2	2	2	2	Vite M.5x12 Screw Vis Schraube	
9	00326R0550	2	2	2	2	Dado M.5 Nut Ecrou Mutter	
10	00926R0840	1	1	1	1	Tirante leva alzavalvola Tie rod Entretoise Zugstange	
11	00296R0680	1	1	—	—	Cuffia per alzavalvola Protection Protection Schutz	
	00296R0770	—	—	1	1	Cuffia per alzavalvola Protection Protection Schutz	
12	0035150350	—	—	1	1	Distanziale puleggia H,23 Spacer Entretoise Distanzstück	
13	0035150390	1	1	—	—	Distanziale puleggia Spacer Entretoise Distanzstück	
	00355R0060	—	—	1	1	Distanziale pul.Recoil H.31,5 Spacer Entretoise Distanzstück	
14	00325R0840	1	1	—	—	Dado M.22x1,5 H.13 Nut Ecrou Mutter	
	00326R0490	—	—	1	1	Dado M.22x1,5 H.13 Nut Ecrou Mutter	
15	00229R0050	1	1	—	—	Convogliatore aria Shroud Coiffe Ventil Ventilatorhaube	
	0025696810	—	—	1	1	Convogliatore aria Air conveyor Coiffe ventil Ventilatorhaube	
16	00000R9580	1	1	1	1	Recoil completo Complete Recoil Recoil complet Ganz Recoil	
17	00692R0430	1	1	1	1	Puleggia innesto Pulley Poulie Anwerfscheibe	
18	00234R0420	1	1	1	1	Coperchio Cover Couvercle Deckel	
19	00541R0140	1	1	1	1	Molla Spring Ressort Feder	
20	0049040380	1	1	1	1	Fune con manopola Cord with knob Corde avec bouton Seil und Griff	
21	00518R0200	1	1	1	1	Manopola Knob Bouton Knopf	
22	0032030210	6	6	6	6	Dado autobloccante M.6 H.7,6 Nut Ecrou Mutter	
23	0076250080	6	6	6	6	Rondella piana D.12x6,5 Washer Rondelle Unterlegscheibe	
24	00555R0490	1	1	1	1	Molla a spirale Spring Ressort Feder	
25	00692R0440	1	1	1	1	Puleggia avv. recoil Pulley Poulie Anwerfscheibe	
26	00495R0720	2	2	2	2	Leva di innesto Lever Levier Hebel	



ACCESSORI A RICHIESTA - FITTINGS UPON REQUEST
ACCESSOIRES SUR DEMANDE - RUBEHÖRE AUF WUNSCH

CATALOGO RICAMBI
SPARE PARTS
TAVOLA
TABLE **9 3**
DATA
DATE **10/2007**

Nr. No.	CODE	MD 150 Q.ty	MD 151 Q.ty	MD 190 Q.ty	MD 191 Q.ty	DENOMINAZIONE - DESCRIPTION - DENOMINATION - BENENNUNG				CT No
27	00555R0500	1	1	1	1	Molla	Spring	Ressort	Feder	
28	0097300180	3	3	3	3	Vite M.6x45	Screw	Vis	Schraube	
29	0075650040	1	1	1	1	Rondella diam. 6	Washer	Rondelle	Scheibe	
30	0032400080	1	1	1	1	Dado M 6	Nut	Écrou	Mutter	

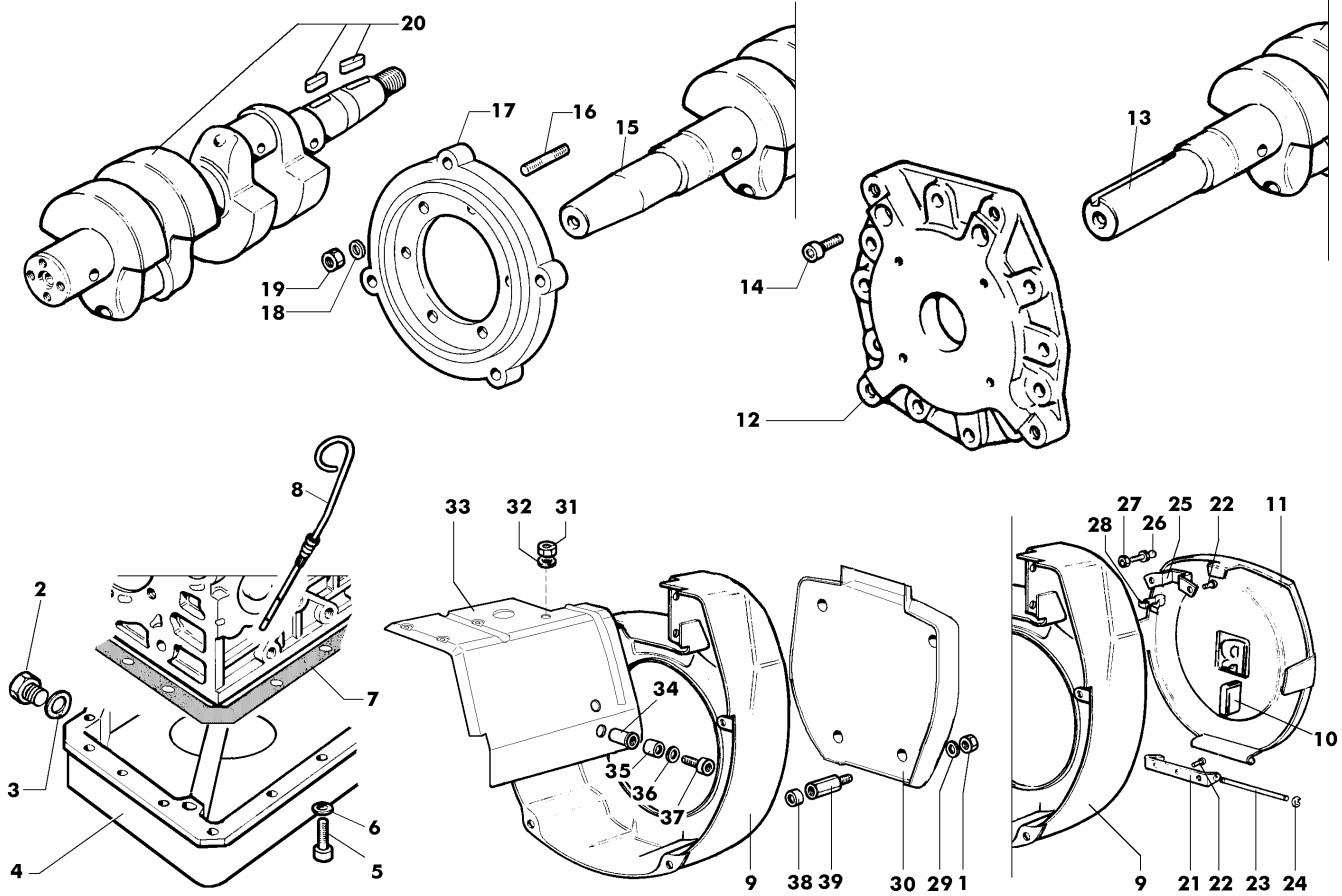

Nr. No.	CODE	MD	MD	MD	MD	DENOMINAZIONE - DESCRIPTION - DENOMINATION - BENENNUNG	CT No		
		150 Q.ty	151 Q.ty	190 Q.ty	191 Q.ty				
	00C25R0400	1	1	—	—	Blocco motore con albero flangiato	Short block	Bloc moteur	Motorbloken
	00C25R0700	—	—	1	1	Blocco motore con albero flangiato	Short block	Bloc moteur	Motorbloken
1	0032030210	4	4	4	4	Dado autobloccante M.6 H.7,6	Nut	Ecrou	Mutter
2	0089650050	2	2	2	2	Tappo M,14x1,5 L.15	Plug	Bouchon	Verschluß
3	0046700610	2	2	2	2	Guarnizione in rame d.14	Gasket	Joint	Dichtung
4	00248R0860	1	1	1	1	Coppa olio lamiera profonda	Oil Pan	Carter Huile	Ölwanne
5	00992R0040	15	15	15	15	Vite M.6x18	Screw	Vis	Schraube
6	0076250080	15	15	15	15	Rondella piana D.12x6,5	Washer	Rondelle	Unterlegscheibe
7	00451R0220	1	1	1	1	Guarnizione coppa olio	Gasket	Joint	Dichtung
8	00076R0590	1	1	1	1	Asta livello olio coppa profonda	Rod	Tige	Stange
9	0025696770	1	1	—	—	Convogliatore STD	Shroud	Coiffe Ventil	Ventilatorhaube
	0025696760	—	—	1	1	Convogliatore aria	Air conveyer	Coiffe ventil	Ventilatorhaube
10	00354R0880	2	2	2	2	Distanziale	Spacer	Entretoise	Distanzstück
11	00688R0230	1	1	1	1	Protezione puleggia	Guard	Protection	Schutz
12	00400R0420	1	1	1	1	Flangia accopp.SAE A/B fil.metri.	Flange	Bride	Flansch
13	00013R0300	1	1	—	—	Albero a gomiti Ext.Cil.1"1/8	Crankshaft	Vilebrequin	Kurbelwelle
	00013R0930	—	—	1	1	Albero a gomiti Ext.Cil.1"1/8	Crankshaft	Vilebrequin	Kurbelwelle
	00013R0430	1	1	—	—	Albero a gomiti 4 SAE	Crankshaft	Vilebrequin	Kurbelwelle
	00011R0030	—	—	1	1	Albero a gomiti 4 SAE	Crankshaft	Vilebrequin	Kurbelwelle
14	0097320740	6	6	6	6	Vite M 8 x 20	Screw	Vis	Schraube
15	00011R0320	1	1	—	—	Albero a gomiti EXT. Gr.Eletr.	Crankshaft	Vilebrequin	Kurbelwelle
	00011R0180	—	—	1	1	Albero a gomiti EXT. Gr.Eletr.	Crankshaft	Vilebrequin	Kurbelwelle
16	00676R0700	6	6	6	6	Prigioniero M.8x20	Stud	Goujon	Stiftschraube
17	00399R0870	1	1	1	1	Flangia accopp. 7" T	Flange	Bride	Flansch
18	0076250120	6	6	6	6	Rondella	Washer	Rondelle	Unterlegscheibe
19	00323R0030	6	6	6	6	Dado M.8 H.8	Nut	Ecrou	Mutter
20	00A21R0270	1	1	—	—	Albero a gomiti a flangia	Crankshaft	Vilebrequin	Kurbelwelle
	00A23R0010	—	—	1	1	Albero a gomiti a flangia	Crankshaft	Vilebrequin	Kurbelwelle
21	00879R0880	1	1	1	1	Supporto copripuleggia	Support	Support	Lager
22	00738R0110	5	5	5	5	Ribattino D.3x8	Rivet	Rivet	Niete



**ACCESSORI A RICHIESTA - FITTINGS UPON REQUEST
ACCESSOIRES SUR DEMANDE - RUBEHÖRE AUF WUNSCH**

CATALOGO RICAMBI
SPARE PARTS
TAVOLA
TABLE **9 5**
DATA
DATE **10/2007**

Nr. No.	CODE	MD 150 Q.ty	MD 151 Q.ty	MD 190 Q.ty	MD 191 Q.ty	DENOMINAZIONE - DESCRIPTION - DENOMINATION - BENENNUNG				CT No
23	00601R0530	1	1	1	1	Perno supporto copripuleggia	Journal	Axe	Zapfen	
24	0011650040	2	2	2	2	Anello seeger D.5	Snap ring	Circlip	Sicherungsring	
25	00613R0170	1	1	1	1	Piastrina	Safety plate	Support	Sicherungsblech	
26	00601R0730	1	1	1	1	Perno x attacco rapido	Journal	Axe	Zapfen	
27	0032400030	1	1	1	1	Dado	Nut	Ecrou	Mutter	
28	00555R0320	1	1	1	1	Molla copripuleggia	Spring	Ressort	Feder	
29	0076250700	4	4	4	4	Rondella piana D.6,5x16 sp.1,5	Washer	Rondelle	Unterlegscheibe	
30	00171R0540	1	1	1	1	Copripuleggia fisso	Pulley guard	Protège poulie	Riemenscheibenschutz	
31	00323R0030	8	8	8	8	Dado M.8 H.8	Nut	Ecrou	Mutter	
32	0076250120	4	4	4	4	Rondella	Washer	Rondelle	Unterlegscheibe	
33	00234R0120	1	1	1	1	Coperchio motore	Cover	Couvercle	Deckel	
34	00742R0150	1	1	1	1	Rivetto filettato M.6	Rivet	Rivet	Niete	
35	0035251170	1	1	1	1	Distanziale D.6,5x16 H.11	Spacer	Entretoise	Distanzstück	
36	0076260510	1	1	1	1	Rondella piana D.6,5x22 sp.2,5	Washer	Rondelle	Unterlegscheibe	
37	0017601380	1	1	1	1	Vite M.6x30	Screw	Vis	Schraube	
38	00354R0020	---	---	4	4	Distanziale D.8,5x13 H.5	Spacer	Entretoise	Distanzstück	
	0076250700	4	4	---	---	Rondella piana D.6,5x16 sp.1,5	Washer	Rondelle	Unterlegscheibe	
39	00326R0430	4	4	4	4	Dado prolunga M.6 H.43	Nut	Ecrou	Mutter	



RUGGERINI MOTORI

Via Cav. Del Lavoro A.Lombardini, 2 - 42100 Reggio Emilia - ITALY

Fax +39 0522 389362 - E-mail: ricambi@lombardini.it - www.ruggerini.it

è un marchio della
 **LOMBARDINI** s.r.l.